

**Pro-face**

by **Schneider** Electric



**SCIGATE AUTOMATION (S) PTE LTD**

No.1 Bukit Batok Street 22 #01-01 Singapore 659592

**Tel: (65) 6561 0488**

**Fax: (65) 6562 0588**

Email: [sales@scigate.com.sg](mailto:sales@scigate.com.sg)

Web: [www.scigate.com.sg](http://www.scigate.com.sg)

Business Hours: Monday - Friday 8.30am - 6.15pm

# LT-4201TM/4301TM Hardware Manual

---

The information provided in this documentation contains general descriptions and/or technical characteristics of the performance of the products contained herein. This documentation is not intended as a substitute for and is not to be used for determining suitability or reliability of these products for specific user applications. It is the duty of any such user or integrator to perform the appropriate and complete risk analysis, evaluation and testing of the products with respect to the relevant specific application or use thereof. Neither Schneider Electric nor any of its affiliates or subsidiaries (hereinafter, referred to as Schneider Electric) shall be responsible or liable for misuse of the information that is contained herein. If you have any suggestions for improvements or amendments or have found errors in this publication, please notify us.

You agree not to reproduce, other than for your own personal, noncommercial use, all or part of this document on any medium whatsoever without permission of Schneider Electric, given in writing. You also agree not to establish any hypertext links to this document or its content.

Schneider Electric does not grant any right or license for the personal and noncommercial use of the document or its content, except for a non-exclusive license to consult it on an "as is" basis, at your own risk. All other rights are reserved.

All pertinent state, regional, and local safety regulations must be observed when installing and using this product. For reasons of safety and to help ensure compliance with documented system data, only the manufacturer should perform repairs to components.

When devices are used for applications with technical safety requirements, the relevant instructions must be followed.

Failure to use Schneider Electric software or approved software with our hardware products may result in injury, harm, or improper operating results.

Failure to observe this information can result in injury or equipment damage.

Copyright © 2018.03 Schneider Electric Japan Holdings Ltd. All Rights Reserved.

# Table of Contents



	<b>Safety Information</b> .....	<b>5</b>
	<b>About the Book</b> .....	<b>7</b>
<b>Part I</b>	<b>LT System</b> .....	<b>9</b>
<b>Chapter 1</b>	<b>LT General Overview</b> .....	<b>11</b>
	Package Contents .....	<b>12</b>
	Parts Identification and Functions .....	<b>14</b>
	System Architecture .....	<b>16</b>
	Certifications and Standards .....	<b>18</b>
	Devices Overview .....	<b>20</b>
<b>Chapter 2</b>	<b>LT System General Implementation Rules</b> .....	<b>23</b>
	Introduction .....	<b>24</b>
	Installation Requirements .....	<b>26</b>
	Environmental Characteristics .....	<b>28</b>
	Wiring Rules and Recommendations .....	<b>30</b>
	Wiring to the DIO Terminal Block .....	<b>34</b>
	Grounding the System .....	<b>36</b>
<b>Chapter 3</b>	<b>LT Description</b> .....	<b>41</b>
3.1	Rear Module Features .....	<b>42</b>
	Clock .....	<b>42</b>
3.2	I/O Management .....	<b>43</b>
	Input Management .....	<b>44</b>
	Output Management .....	<b>45</b>
<b>Chapter 4</b>	<b>Device Connectivity</b> .....	<b>47</b>
	System Design .....	<b>48</b>
	Interface Accessories .....	<b>51</b>
<b>Chapter 5</b>	<b>LT Installation</b> .....	<b>53</b>
5.1	Mechanical Requirements .....	<b>54</b>
	Display Module and Rear Module Dimensions .....	<b>55</b>
	Rear Module Dimensions .....	<b>58</b>
	Separation Cable Dimensions .....	<b>59</b>
	Panel Cut-Out Dimensions and Installation .....	<b>60</b>
	Installation Procedures .....	<b>63</b>
	Mounting Positions .....	<b>68</b>
	Mounting Clearances .....	<b>69</b>
	DIN Rail .....	<b>71</b>
	Installing and Removing the Rear Module on a DIN Rail .....	<b>72</b>
5.2	Electrical Requirements .....	<b>75</b>
	Power Supply Characteristics and Wiring .....	<b>76</b>
	Connecting the Power Cord .....	<b>78</b>
	Connecting the Power Supply .....	<b>80</b>

---

5.3	USB Port .....	82
	USB Data Transfer Cable - USB Driver Installation .....	83
	USB (Type A) .....	84
	USB (mini-B) .....	86
	<b>Part II LT Unit and Display Modules .....</b>	<b>89</b>
<b>Chapter 6</b>	<b>LT-4201TM/4301TM (Modular Type DIO) .....</b>	<b>91</b>
	Presentation .....	92
	Digital Inputs .....	94
	Digital Outputs .....	96
<b>Chapter 7</b>	<b>LT-4201TM/4301TM (Modular Type Analog) .....</b>	<b>99</b>
	Presentation .....	100
	Digital Inputs .....	102
	Digital Outputs .....	104
	Analog Inputs and Analog Outputs .....	107
<b>Chapter 8</b>	<b>Display Modules .....</b>	<b>111</b>
	Panel Overview .....	111
	<b>Part III LT Controller Panels .....</b>	<b>115</b>
<b>Chapter 9</b>	<b>Communication Interface .....</b>	<b>117</b>
	Ethernet Port .....	118
	CANopen Master Unit .....	120
	Serial Interface (COM1) .....	123
<b>Chapter 10</b>	<b>Specifications .....</b>	<b>125</b>
10.1	General Specifications .....	126
	General Specifications .....	126
10.2	Functional Specifications .....	128
	Display .....	129
	Digital Inputs .....	130
	Digital Outputs .....	132
	Analog Inputs and Analog Outputs .....	134
	Internal Circuits .....	138
	Memory and Touch Panel .....	140
<b>Chapter 11</b>	<b>Maintenance .....</b>	<b>141</b>
	Regular Cleaning .....	142
	Periodic Check Points .....	143
	<b>Index .....</b>	<b>145</b>

# Safety Information



## Important Information

### NOTICE

Read these instructions carefully, and look at the equipment to become familiar with the device before trying to install, operate, or maintain it. The following special messages may appear throughout this documentation or on the equipment to warn of potential hazards or to call attention to information that clarifies or simplifies a procedure.



The addition of this symbol to a “Danger” or “Warning” safety label indicates that an electrical hazard exists which will result in personal injury if the instructions are not followed.



This is the safety alert symbol. It is used to alert you to potential personal injury hazards. Obey all safety messages that follow this symbol to avoid possible injury or death.

## DANGER

**DANGER** indicates a hazardous situation which, if not avoided, **will result in death** or serious injury.

## WARNING

**WARNING** indicates a hazardous situation which, if not avoided, **could result in death** or serious injury.

## CAUTION

**CAUTION** indicates a hazardous situation which, if not avoided, **could result** in minor or moderate injury.

## NOTICE

**NOTICE** is used to address practices not related to physical injury.

### PLEASE NOTE

Electrical equipment should be installed, operated, serviced, and maintained only by qualified personnel. No responsibility is assumed by Schneider Electric for any consequences arising out of the use of this material.

A qualified person is one who has skills and knowledge related to the construction and operation of electrical equipment and its installation, and has received safety training to recognize and avoid the hazards involved.



# About the Book



## At a Glance

### Document Scope

The purpose of this document is to:

- Show you how to install and operate your LT.
- Show you how to connect the LT to a programming device equipped with GP-Pro EX.
- Help you understand how to interface the LT and other devices.
- Help you become familiar with the LT features.

### Global Code

A global code is assigned to every Pro-face product as a universal model number.

For more information on product models and their matching global codes, please refer to the following URL:

<http://www.pro-face.com/trans/en/manual/1003.html>

### Validity Note

This documentation is valid for GP-Pro EX V4.0 or later.

The characteristics presented in this manual should be the same as those that appear online. In line with our policy of constant improvement we may revise content over time to improve clarity and accuracy. In the event that you see a difference between the manual and online information, use the online information as your reference.

### Related Documents

Title of Documentation	Reference Number
GP-Pro EX Reference Manual Maintenance/Troubleshooting Guide	
GP-Pro EX Device/PLC Connection Manual	

You can download these technical publications and other technical information from our support site at <http://www.pro-face.com/trans/en/manual/1001.html>.

### Product Related Information



#### HAZARD OF ELECTRIC SHOCK, EXPLOSION OR ARC FLASH

- Disconnect all power from all equipment including connected devices prior to removing any covers or doors, or installing or removing any accessories, hardware, cables, or wires except under the specific conditions specified in the appropriate hardware guide for this equipment.
- Always use a properly rated voltage sensing device to confirm the power is off where and when indicated.
- Replace and secure all covers, accessories, hardware, cables, and wires and confirm that a proper ground connection exists before applying power to the unit.
- Use only the specified voltage when operating this equipment and any associated products.

**Failure to follow these instructions will result in death or serious injury.**

---

This equipment has been designed to operate outside of any hazardous location. Only install this equipment in zones known to be free of a hazardous atmosphere.

## DANGER

### POTENTIAL FOR EXPLOSION

Install and use this equipment in non-hazardous locations only.

**Failure to follow these instructions will result in death or serious injury.**

## WARNING

### LOSS OF CONTROL

- Consider the potential failure modes of control paths in the machine control system design, such as:
  - The possibility of backlight failure,
  - Unanticipated link transmission delays or failures,
  - The operator being unable to control the machine,
  - The operator making errors in the control of the machine.
- Design outside the LT operations such as emergency stop, safety circuits, interlocks that operate with opposing actions such as clockwise/counterclockwise rotation, and circuits that prevent machine damage with positioning limits on top, bottom, and movement.
- For important operations handled by switches, design your system to use a separate hardware device. This is to reduce the occurrence of incorrect outputs or malfunctions.
- Observe all accident prevention regulations and local safety guidelines.<sup>1</sup>
- Test individually and thoroughly each implementation of the equipment for correct operation before service.

**Failure to follow these instructions can result in death, serious injury, or equipment damage.**

<sup>1</sup> For additional information, refer to NEMA ICS 1.1 (latest edition), "Safety Guidelines for the Application, Installation, and Maintenance of Solid State Control" and to NEMA ICS 7.1 (latest edition), "Safety Standards for Construction and Guide for Selection, Installation and Operation of Adjustable-Speed Drive Systems" or their equivalent governing your particular location.

## WARNING

### UNINTENDED EQUIPMENT OPERATION

- Only use software approved by Schneider Electric for use with this equipment.
- Check your application program every time you change the physical hardware configuration, and make updates as required.

**Failure to follow these instructions can result in death, serious injury, or equipment damage.**



---

# Part I

## LT System

---

### Overview

This part describes how to use LT system.

### What Is in This Part?

This part contains the following chapters:

Chapter	Chapter Name	Page
1	LT General Overview	11
2	LT System General Implementation Rules	23
3	LT Description	41
4	Device Connectivity	47
5	LT Installation	53



---

# Chapter 1

## LT General Overview

---

### Overview

This chapter provides general information about the LT system architecture and its components.

### What Is in This Chapter?

This chapter contains the following topics:

Topic	Page
Package Contents	12
Parts Identification and Functions	14
System Architecture	16
Certifications and Standards	18
Devices Overview	20

## Package Contents

### LT Package Contents

Verify that all items shown in the figure are present in your package:

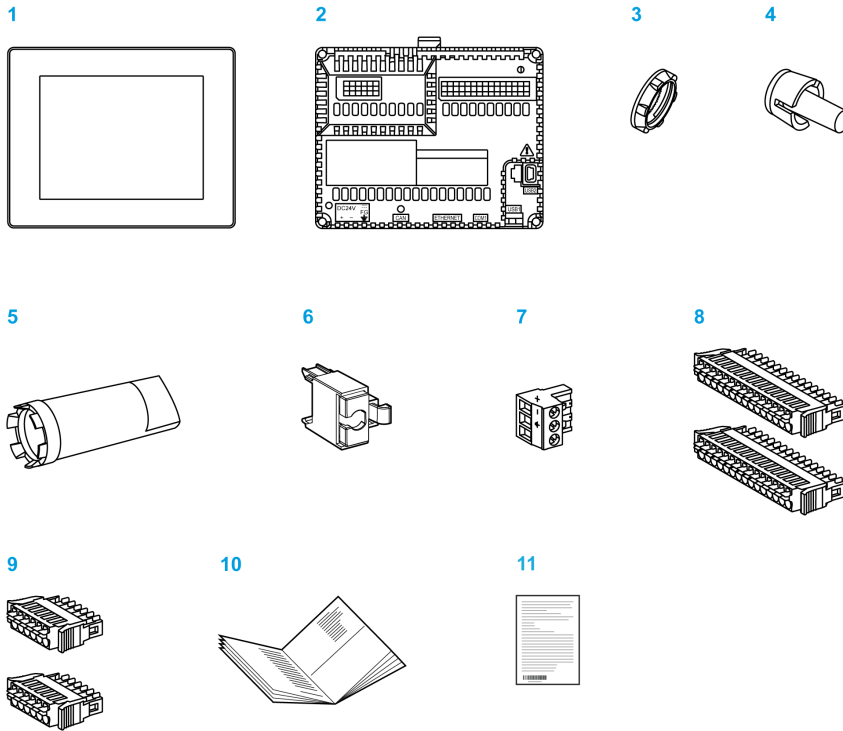

- 1 Display module
- 2 Rear module
- 3 Display installation nut (attached to the display module)
- 4 Anti-rotation tee
- 5 Socket wrench
- 6 USB clamp type A
- 7 DC power supply connector
- 8 I/O connector 15-pin x 2
- 9 I/O connector 6-pin x 2
- 10 LT-4201TM/4301TM Installation Guide
- 11 Warning / Caution information

### Display Module Package Contents

Verify that all items shown in the figure are present in your package:

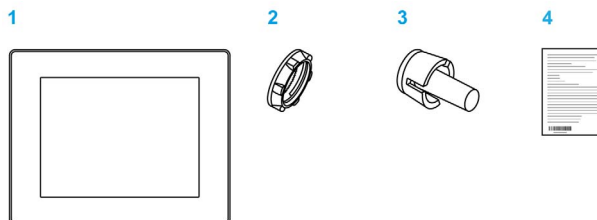

- 1 Display module
- 2 Display installation nut (attached to the display module)
- 3 Anti-rotation tee

4 Warning / Caution information

**Rear Module Package Contents**

Verify that all items shown in the figure are present in your package:

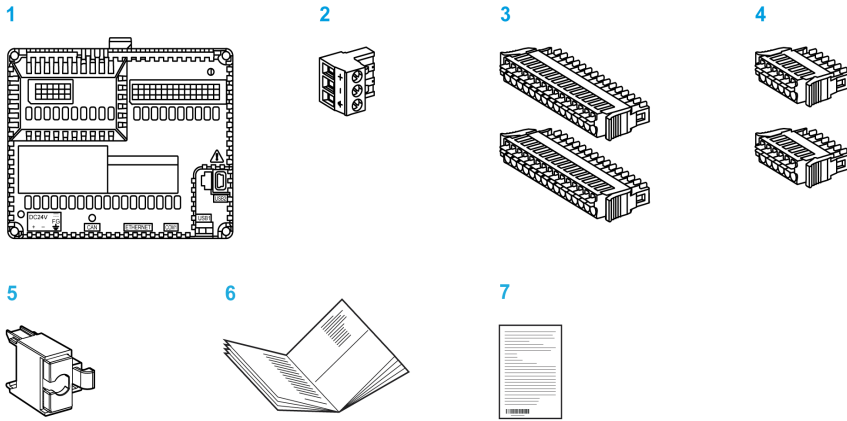

- 1 Rear module
- 2 DC power supply connector
- 3 I/O connector 15-pin x 2
- 4 I/O connector 6-pin x 2
- 5 USB clamp type A
- 6 LT-4201TM/4301TM Installation Guide
- 7 Warning / Caution information

**Product Label Sticker**

You can identify the product version (PV) and the revision level (RL) from the product label.

The following diagram is a representation of a typical label:

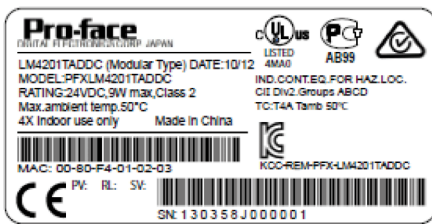

LT4200/4300 Series model which unit's version number (PV) is 02 or later can also be used as Rear Module.

## Parts Identification and Functions

### LT-4201TM/4301TM Parts Identification

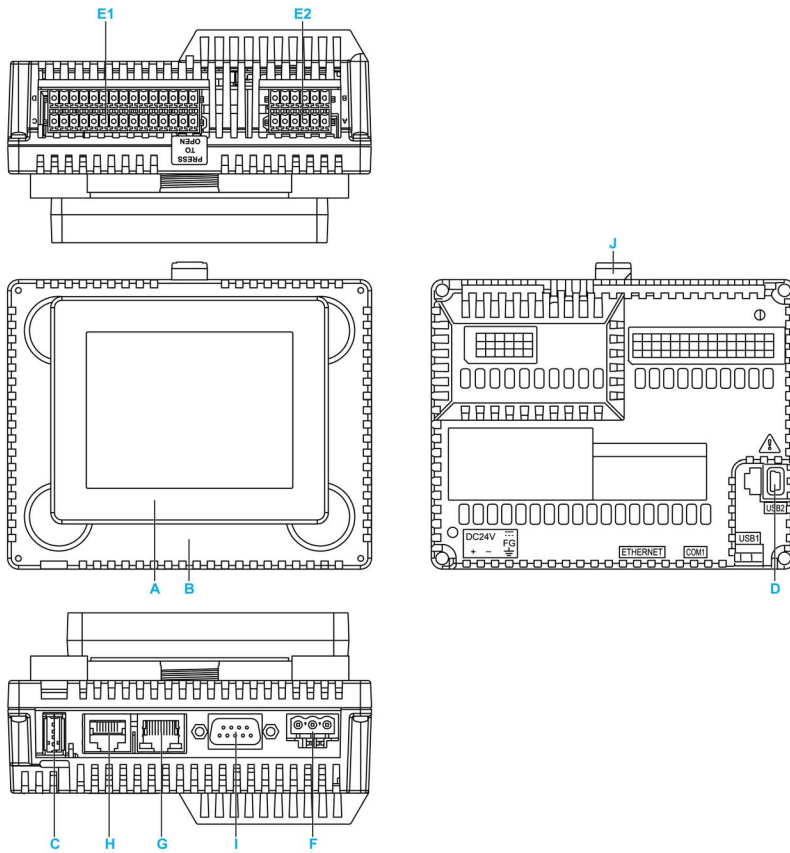

Part	Description
A	Display module
B	Rear module (see page 89)
C	USB (type A) interface connector (USB1) (see page 82)
D	USB (type mini B) interface connector (USB2)
E1	I/O terminal block 1
E2	I/O terminal block 2
F	DC power supply connector (see page 76)
G	Ethernet interface
H	Serial link (RS-232C/485) (see page 123)
I	CANopen interface connector
J	Yellow button lock

## Rear Module Parts Identification

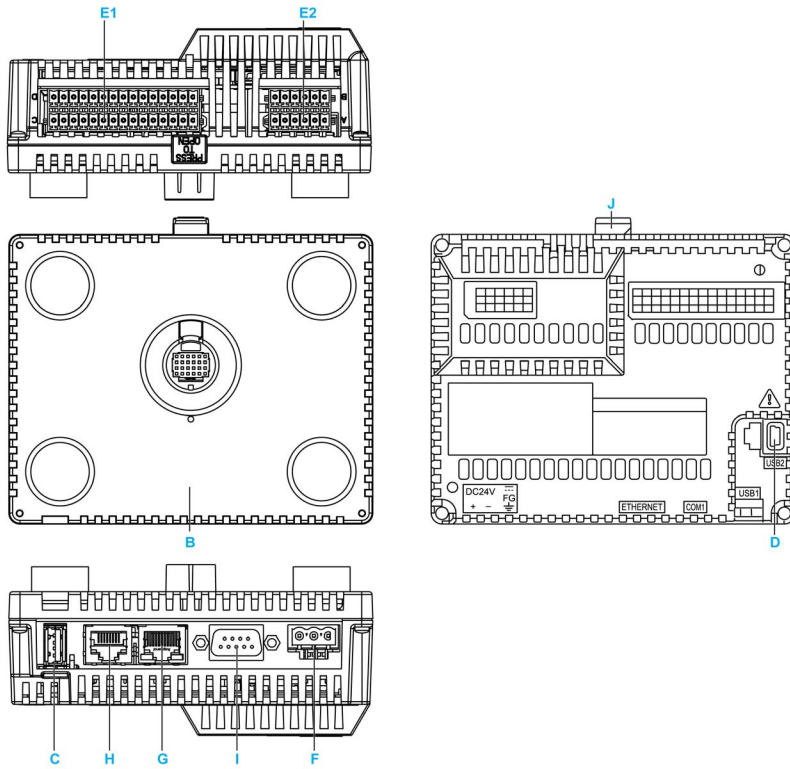

Part	Description
B	Rear module ( <i>see page 89</i> )
C	USB (type A) interface connector (USB1) ( <i>see page 82</i> )
D	USB (type mini B) interface connector (USB2)
E1	I/O terminal block 1
E2	I/O terminal block 2
F	DC power supply connector ( <i>see page 76</i> )
G	Ethernet interface
H	Serial link (RS-232C/485) ( <i>see page 123</i> )
I	CANopen interface connector
J	Yellow button lock

## System Architecture

### Introduction

The LT system is a compact control system with the Panel and I/O embedded. The LT system offers an all-in-one solution for an optimized configuration and an expandable architecture.

### Architecture Example

The following figure provides an example of the LT hardware environment:

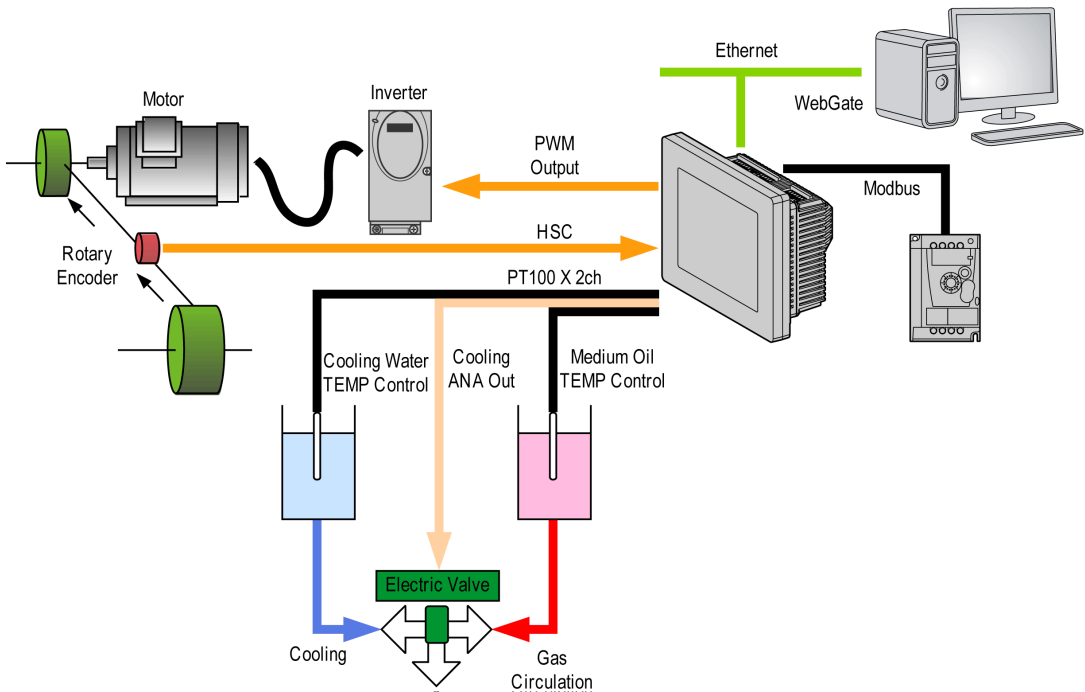

### LT System Architecture

Combine the following modules and cables to design a versatile and effective system:

- Display module that provides the display function (see page 111)
- Rear module that provides the logic and HMI functions
- Display module/rear module separation cable that enables you to install the rear and display modules separately.



The figure shows the components of the LT system:

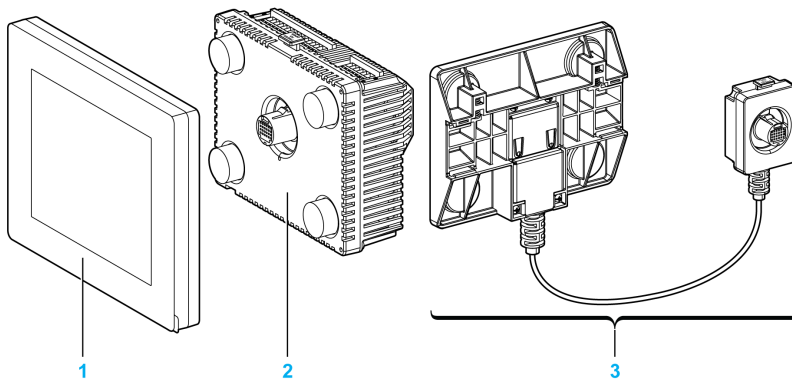

- 1 Display module
- 2 Rear module
- 3 Display module/rear module separation cable

### Display Module/Rear Module Separation Cable Description

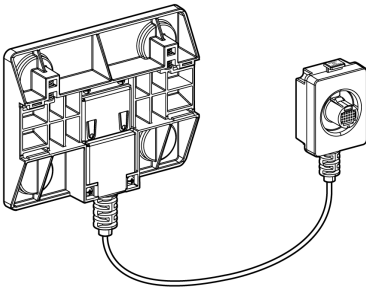

Use this display module/rear module separation cable when the rear module is installed on a DIN rail:

- The outer diameter of the cable is 8 mm (0.31 in.).
- There are 2 types of cable: 3 m (9.84 ft) and 5 m (16.4 ft).
- To assemble this product, you need 20 mm (0.78 in.) more space to bend the cable in the end of the rubber.

## Certifications and Standards

### Introduction

Schneider Electric submitted this product for independent testing and qualification by third party listing agencies. These agencies have certified this product as meeting the following standards.

For information on Standards and Regulations, such as certified models and certificates, please check the product marking or the following URL.

<http://www.pro-face.com/trans/en/manual/1002.html>

### Agency Certifications for LT Unit

LT is manufactured in accordance with UL 508 and CSA C22.2 n°142 for Industrial Control Equipment.

For use on a flat surface of a Type 1, Type 4X (indoor use only) enclosure.

### Hazardous Substances

This product is a device for use in factory systems. When using this product in a system, the system should comply with the following standards in regards to the installation environment and handling:

- WEEE, Directive 2012/19/EU
- RoHS, Directives 2011/65/EU
- RoHS China, Standard GB/T 26572
- REACH regulation EC 1907/2006

### CE Markings

This product conforms to the necessary requirements of the following Directives for applying the CE label:

- 2006/95/EC Low Voltage Directive
- 2004/108/EC EMC Directive

This conformity is based on compliance with IEC61131-2.

## CAUTION

### ENVIRONMENTAL HAZARDS TO THE EQUIPMENT

- Allow the device to reach the surrounding air temperature, not exceeding 50 °C (122 °F), before turning the device on.
- Do not turn on the device if condensation has occurred inside the device. After it is completely dry again, the device may be turned on.
- Do not expose the device to direct sunlight.
- Do not obstruct the vents in the device casing.
- Remove any dust from the device before turning it on.
- Ensure that the cable installation fasteners are not damaged. Replace them, if necessary.
- Mount the device into an enclosure that meets the IP65 level of protection.

**Failure to follow these instructions can result in injury or equipment damage.**

**⚠ WARNING**

**RISK OF EXPLOSION IN HAZARDOUS LOCATIONS**

- Verify that the power, input, and output (I/O) wiring are in accordance with Class I, Division 2 wiring methods.
- Do not substitute components that may impair compliance to Class I, Division 2.
- Do not connect or disconnect equipment unless power has been switched off or the area is known to be non-hazardous.
- Securely lock externally connected units and each interface before turning on the power supply.
- Do not, connect, or disconnect USB cable unless area is known to be non-hazardous.
- Potential electrostatic charging hazard: wipe the front panel of the terminal with a damp cloth before turning ON.

**Failure to follow these instructions can result in death, serious injury, or equipment damage.**

Interfaces are: COM1, Ethernet, USB1 and USB2.

**⚠ WARNING**

**RISK OF EXPLOSION IN HAZARDOUS LOCATIONS**

- Do not disconnect while circuit is live.
- Potential electrostatic charging hazard: wipe the front panel of the terminal with a damp cloth before turning ON.

**Failure to follow these instructions can result in death, serious injury, or equipment damage.**

**KC Markings**

해당 무선설비는 운용 중 전파혼신 가능성이 있음

사용자안내문

기종별	사용자안내문
A급 기기 (업무용 방송통신기자재)	이 기기는 업무용(A급) 전자파적합기기로서 판매자 또는 사용자는 이 점을 주의하시기 바라며, 가정외의 지역에서 사용하는 것을 목적으로 합니다.

해당 무선설비는 전파혼신 가능성이 있으므로 인명안전과 관련된 서비스는 할 수 없습니다

## Devices Overview

### Overview

LT has various features. This LT can service a wide range of applications.

The software configuration and programming is accomplished with GP-Pro EX and is described in the GP-Pro EX Reference Manual.

### LT Range

Series	Model Names	Models	Digital Input	Digital Output	Analog Input	Analog Output	Screen Size
LT4000 Series	LT-4201TM (Modular Type DIO)	PFXLM4201TADDC PFXLM4201TADDK	20 Points Standard Input (2 Points for Fast Input)	10 Points Standard Output and 2 Points Fast Output	None	None	3.5 in.
	LT-4301TM (Modular Type DIO)	PFXLM4301TADDC PFXLM4301TADDK					5.7 in.
	LT-4000M (Modular Type DIO)	PFXLM4B01DDC PFXLM4B01DDK					None
	LT-4201TM (Modular Type Analog)	PFXLM4201TADAC PFXLM4201TADAK	12 Points Standard Input (2 Points for Fast Input)	6 Points Standard Output and 2 Points Fast Output	2 ch analog inputs (13-bit) and 2 ch analog inputs (16-bit) for Thermocouple	2 ch analog outputs (12-bit)	3.5 in.
	LT-4301TM (Modular Type Analog)	PFXLM4301TADAC PFXLM4301TADAK					5.7 in.
	LT-4000M (Modular Type Analog)	PFXLM4B01DAC PFXLM4B01DAK					None
	3.5 inch display module	PFXXM4200TP	None				3.5 in.
	5.7 inch display module	PFXXM4300TP	None				5.7 in.

**NOTE:** Fast Input and Fast Output are generic terms for the following functions:  
 Fast Input: High-speed Counter Input and Pulse Catch Input.  
 Fast Output: Pulse Output, PWM Output and High-speed Counter Synchronize Output.

### Display Module/Rear Module Separation Cable Range

Reference	Cable Length
PFXZXMADSM31	3 m (9.84 ft.)
PFXZXMADSM51	5 m (16.40 ft.)
<b>NOTE:</b> The outer diameter of the cable is 8 mm (0.13 in.). To assemble this product, you need 20 mm (0.78 in.) more space to bend the cable in the end of the rubber.	

**Model Name Identification**

The table presents the model name identification numbers:

Legend	Number/Letter	Description
<p style="text-align: center;"> <span style="border-bottom: 1px solid black; padding: 0 5px;">A</span> <span style="border-bottom: 1px solid black; padding: 0 5px;">B</span> <span style="border-bottom: 1px solid black; padding: 0 5px;">C</span> <span style="border-bottom: 1px solid black; padding: 0 5px;">D</span> <span style="border-bottom: 1px solid black; padding: 0 5px;">E</span> <span style="border-bottom: 1px solid black; padding: 0 5px;">F</span> <span style="border-bottom: 1px solid black; padding: 0 5px;">G</span> </p>		
A	2	LT-4201TM (3.5-inch): QVGA (320 x 240 dots)
	3	LT-4301TM (5.7-inch): QVGA (320 x 240 dots)
	B	No display (rear module)
B	01	RS-232C/RS-485
C	T	TFT color LCD
D	A	Analog touch panel
E	D	DC type power supply is used
F	A	Analog I/O with Digital I/O
	D	Digital I/O
G	C	Source output type
	K	Sink output type

**Key Features**

**Programming languages**

The LT is supported by and programmed with the GP-Pro EX, which supports the following IEC61131-3 programming languages:

- IL: Instruction List
- LD: Ladder Diagram

**Power Supply** (see page 75)

The power supply of the LT is 24 Vdc.

**Clock** (see page 140)

The LT includes a Clock (RTC).

**Memory** (see page 140)

**Embedded Input/Output**

The following embedded I/O types are available. The I/O you can use depends on the model in use, see LT Range (see page 20):

- Standard Input
- Fast Input
- Standard Output
- Fast Output
- Analog Input
- Temperature Input
- Analog Output

### **Communication Interface**

4 types of communication interfaces are available:

- Ethernet interface
- USB interface
- Serial link interface
- CANopen interface

For more details, refer to the chapter Communication Interface (*see page 117*).

---

# Chapter 2

## LT System General Implementation Rules

---

### Overview

This chapter describes the installation requirements, wiring rules and recommendations, and the environmental specifications of the controller.

### What Is in This Chapter?

This chapter contains the following topics:

Topic	Page
Introduction	24
Installation Requirements	26
Environmental Characteristics	28
Wiring Rules and Recommendations	30
Wiring to the DIO Terminal Block	34
Grounding the System	36

## Introduction

### Before You Begin

#### **WARNING**

##### **UNGUARDED MACHINERY CAN CAUSE SERIOUS INJURY**

- Do not use this controller and related software on equipment that does not have point-of-operation protection.
- Do not reach into machinery during operation.

**Failure to follow these instructions can result in death, serious injury, or equipment damage.**

The LT controller and related software is used to control various industrial processes. The type or model of automation equipment suitable for each application will vary depending on factors such as the control function required, degree of protection required, production methods, unusual conditions, government regulations, and so on, in some applications, more than one processor may be required, as when backup redundancy is needed.

Only the user can be aware of all the conditions and factors present during the setup, operation, and maintenance of the machine; therefore, only the user can determine the automation equipment and the related safeties and interlocks that can be properly used. When selecting automation and control equipment and related software for a particular application, the user should refer to the applicable local and national standards and regulations.

In some applications, additional operator protection such as point-of-operation guarding must be provided. This is necessary if the operator's hands and other parts of the body are free to enter pinch points or other hazardous areas and serious injury can occur. The LT controller and related software products alone cannot protect an operator from injury. For this reason, this equipment cannot be substituted for or take the place of point-of-operation protection. Ensure that appropriate safeties and mechanical/electrical interlocks related to point of operation protection have been installed and are operational before placing the equipment into service. All interlocks and safeties related to point-of-operation protection must be coordinated with the related automation equipment and software programming.

#### **WARNING**

##### **UNINTENDED EQUIPMENT OPERATION**

- Use appropriate safety interlocks where personnel and/or equipment hazards exist.
- Install and operate this equipment in an enclosure appropriately rated for its intended environment.
- Use the sensor and actuator power supplies only for supplying power to the sensors or actuators connected to the module.
- Power line and output circuits must be wired and fused in compliance with local and national regulatory requirements for the rated current and voltage of the particular equipment.
- Do not use this equipment in safety-critical machine functions.
- Do not disassemble, repair, or modify this equipment.
- Do not connect any wiring to unused connections, or to connections designated as Not Connected (N.C.).

**Failure to follow these instructions can result in death, serious injury, or equipment damage.**



**NOTE:** Coordination of safeties and mechanical/electrical interlocks for point-of-operation protection is outside the scope of this document, and are not included in any wiring diagrams, installation examples, application examples, programming examples, or other representations that may be included in this and other related documents.

### Start-Up and Test

Before using electrical control and automation equipment for regular operation after installation, the system should be given by a start-up test qualified personnel to verify correct operation of the equipment. It is important that the arrangements for such a check be made and that enough time is allowed to perform complete and satisfactory testing.

## CAUTION

### EQUIPMENT OPERATION HAZARD

- Verify that all installation and set up procedures have been completed.
- Before operational tests are performed, remove all blocks or other temporary holding means used for shipment from all component devices.
- Remove tools, meters, and debris from equipment.

**Failure to follow these instructions can result in injury or equipment damage.**

Follow all start-up tests recommended in the equipment documentation. Store all equipment documentation for future references.

Verify that the completed system is free from all short circuits and grounds, except those grounds installed according to local and national regulations. If high-potential voltage testing is necessary, follow recommendations in equipment documentation to help prevent accidental equipment damage or injury.

Before energizing equipment:

- Remove tools, meters, and debris from equipment.
- Close the equipment enclosure door.
- Remove ground from incoming power lines.
- Perform all start-up tests recommended by the manufacturer.

### Operation and Adjustments

There are hazards that can be encountered if this equipment is improperly operated or adjusted, regardless of the care exercised in the design and manufacture of equipment or in the selection and ratings of components. It may be possible to mis-adjust this equipment and thereby produce unintended consequences. Only those operational adjustments required by the operator should be accessible to the operator. Access to other controls should be restricted to prevent unauthorized changes in operating characteristics or machine behavior. Restrict access to such adjustments only to qualified personnel familiar with the machinery in use, and familiar with the instructions of equipment manufacturers for all of the electrical equipment employed. Use the instructions from the manufacturers as a guide for functional, electrical, or other like adjustments.

## Installation Requirements

### Before Starting

Read and understand this chapter before beginning the installation of your LT.

### Disconnecting Power

All options and modules should be assembled and installed before installing the control system on a mounting rail, onto a mounting plate or in a panel. Remove the control system from its mounting rail, mounting plate or panel before disassembling the equipment.

## DANGER

### HAZARD OF ELECTRIC SHOCK, EXPLOSION OR ARC FLASH

- Disconnect all power from all equipment including connected devices prior to removing any covers or doors, or installing or removing any accessories, hardware, cables, or wires except under the specific conditions specified in the appropriate hardware guide for this equipment.
- Always use a properly rated voltage sensing device to confirm the power is off where and when indicated.
- Replace and secure all covers, accessories, hardware, cables, and wires and confirm that a proper ground connection exists before applying power to the unit.
- Use only the specified voltage when operating this equipment and any associated products.

**Failure to follow these instructions will result in death or serious injury.**

### Programming Considerations

## WARNING

### UNINTENDED EQUIPMENT OPERATION

- Only use software approved by Schneider Electric for use with this equipment.
- Check your application program every time you change the physical hardware configuration, and make any updates as required.

**Failure to follow these instructions can result in death, serious injury, or equipment damage.**

### Operating Environment

This equipment has been designed to operate outside of any hazardous location. Only install this equipment in zones known to be free of a hazardous atmosphere.

## DANGER

### POTENTIAL FOR EXPLOSION

Install and use this equipment in non-hazardous locations only.

**Failure to follow these instructions will result in death or serious injury.**

 **WARNING****UNINTENDED EQUIPMENT OPERATION**

- Use appropriate safety interlocks where personnel and/or equipment hazards exist.
- Install and operate this equipment in an enclosure appropriately rated for its intended environment.
- Use the sensor and actuator power supplies only for supplying power to the sensors or actuators connected to the module.
- Power line and output circuits must be wired and fused in compliance with local and national regulatory requirements for the rated current and voltage of the particular equipment.
- Do not use this equipment in safety-critical machine functions.
- Do not disassemble, repair, or modify this equipment.
- Do not connect any wiring to unused connections, or to connections designated as Not Connected (N.C.).

**Failure to follow these instructions can result in death, serious injury, or equipment damage.**

## Environmental Characteristics

### Enclosure Requirements

LT system components are designed as Zone B, Class A industrial equipment according to IEC/CISPR Publication 11. If they are used in environments other than those described in the standard, or in environments that do not meet the specifications in this manual, the ability to meet electromagnetic compatibility requirements in the presence of conducted and/or radiated interference may be reduced.

All LT system components meet European Community (CE) requirements for open equipment as defined by EN61131-2. You must install them in an enclosure designed for the specific environmental conditions and to minimize the possibility of unintended contact with hazardous voltages. Use a metal enclosure to improve the electromagnetic immunity of your LT system. Use enclosures with a keyed locking mechanism to minimize accidents

### Environmental Characteristics

LT meets CE requirements as indicated in the table below, and is intended for use in a Pollution Degree 2 industrial environment.

The table below gives the general environmental characteristics:

Characteristic	Specification	
Standard compliance	IEC61131-2	
Ambient operating temperature for the display and the rear module	Horizontal installation	0...50°C (32...122°F)
	Vertical installation	0...40°C (32...104°F)
Storage temperature	- 20...60°C (- 4...140°F)	
Storage altitude	0...10,000 m (0...32,808 ft)	
Operating altitude	0...2,000 m (0...6,560 ft)	
Surrounding Air and Storage Humidity	5...85% w/o condensation (non-condensing, wet bulb temperature 39°C (102.2°F) or less)	
Degree of pollution	IEC60664	2
Degree of protection	IEC61131-2	IP20 with protective covers in place
Corrosive gases	Free of corrosive gases	
Dust	≤ 0.1 mg/m <sup>3</sup> (10 <sup>-7</sup> oz/ft <sup>3</sup> ) (non-conductive levels)	
Atmospheric pressure (Operating Altitude)	800...1,114 hPa (2000 m (6,561 ft) or lower)	
Vibration resistance	Mounted on a DIN rail	3.5 mm (0.138 in.) fixed amplitude from 5...8.4 Hz 9.8 m/s <sup>2</sup> (1 g <sub>n</sub> ) fixed acceleration from 8.4...150 Hz
	Mounted on a panel	3.5 mm (0.138 in.) fixed amplitude from 5...8.6 Hz 9.8 m/s <sup>2</sup> (1 g <sub>n</sub> ) fixed acceleration from 8.6...150 Hz
Mechanical shock resistance	Mounted on a DIN rail	147 m/s <sup>2</sup> (15 g <sub>n</sub> ) for a duration of 11 ms
	Mounted on a panel	147 m/s <sup>2</sup> (15 g <sub>n</sub> ) for a duration of 6 ms

### Electromagnetic Susceptibility

The LT system meets electromagnetic susceptibility specifications as indicated in the table:

Characteristic	Specification	Range
Electrostatic discharge	IEC/EN 61000-4-2	8 kV (air discharge) 6 kV (contact discharge)
Radiated radio frequency electromagnetic fields	IEC/EN 61000-4-3	10 V/m (80 MHz...3 GHz)
Fast transients / Burst noise	IEC/EN 61000-4-4	Power lines: 2 kV Digital I/O: 1 kV Relay outputs: 2 kV Ethernet line: 1 kV COM line: 1 kV CAN line: 1 kV
Surge immunity	IEC/EN 61000-4-5	Power supply: CM: 1 kV; DM: 0.5 kV Digital I/O: CM: 1 kV; DM: 0.5 kV Shielded cable: 1 kV CM = common drive DM = differential drive
Conducted disturbances induced by radio- frequency fields	IEC/EN 61000-4-6	10 Veff (0.15...80 MHz)
Mains terminal disturbance voltage	EN 55011 (IEC/CISPR11)	150...500 kHz, quasi peak 79 dB $\mu$ V
		500 kHz...30 MHz, quasi peak 73 dB $\mu$ V
Electric field strength	EN 55011 (IEC/CISPR11)	30...230 MHz, quasi peak 10 m@40 dB $\mu$ V/m
		230 MHz...1 GHz, quasi peak 10 m@47 dB $\mu$ V/m

## Wiring Rules and Recommendations

### Introduction

There are several rules that must be followed when wiring the LT system.

### Wiring Guidelines

 <b>DANGER</b>
<p><b>HAZARD OF ELECTRIC SHOCK, EXPLOSION OR ARC FLASH</b></p> <ul style="list-style-type: none"> <li>• Disconnect all power from all equipment including connected devices prior to removing any covers or doors, or installing or removing any accessories, hardware, cables, or wires except under the specific conditions specified in the appropriate hardware guide for this equipment.</li> <li>• Always use a properly rated voltage sensing device to confirm the power is off where and when indicated.</li> <li>• Replace and secure all covers, accessories, hardware, cables, and wires and confirm that a proper ground connection exists before applying power to the unit.</li> <li>• Use only the specified voltage when operating this equipment and any associated products.</li> </ul> <p><b>Failure to follow these instructions will result in death or serious injury.</b></p>

The following rules must be applied when wiring a LT system:

- I/O and communication wiring must be kept separate from the power wiring. Route these 2 types of wiring in separate cable ducting.
- Verify that the operating conditions and environment are within specification.
- Use proper wire sizes to meet voltage and current requirements.
- Use copper conductors.
- Use twisted-pair, shielded cables for analog, and/or fast I/O.
- Use twisted-pair, shielded cables for networks, and fieldbus.
- For the power connector, refer to DC power supply wiring diagram (see page 77).
- When terminals A2 and B2 (signal name: Q1, Q0) are wired to external I/O, use the same power source for external I/O and the LT. Refer to Power Supply Connections.
- If you use a temperature sensor with thermocouple inputs, make sure you use the compensation cable.
- Prevent temperature changes to the thermocouple connection terminal. Correct temperature measurement may not be possible if the thermocouple cold junction (LT's thermocouple compensation wiring to the connection terminal) experiences temperature changes.

 <b>WARNING</b>
<p><b>IMPROPER GROUNDING CAN CAUSE UNINTENDED EQUIPMENT OPERATION</b></p> <ul style="list-style-type: none"> <li>• Use cables with insulated shielded jackets for analog I/O, fast I/O and communication signals.</li> <li>• Ground shielded cables for analog I/O, fast I/O and communication signals at a single point <sup>1</sup>.</li> <li>• Always comply with local wiring requirements regarding grounding of cable shields.</li> </ul> <p><b>Failure to follow these instructions can result in death, serious injury, or equipment damage.</b></p>

<sup>1</sup>Multipoint grounding is permissible if connections are made to an equipotential ground plane dimensioned to help avoid shielded cable damage in the event of power system short circuit currents.

For more details, refer to Grounding Shielded Cables (see page 36).

The wire sizes to use with the removable terminal blocks is 0.20 to 0.81 mm<sup>2</sup> (AWG 24 to 18).

**⚠ DANGER**

**FIRE HAZARD**

Use only the recommended wire sizes for I/O channels and power supplies.

**Failure to follow these instructions will result in death or serious injury.**

**Terminal Block**

Not plugging the terminal block into rear module correctly can cause an electric shock or unintended operation of the application and/or can damage the rear module.

**⚠ DANGER**

**UNINTENDED EQUIPMENT OPERATION OR ELECTRIC SHOCK**

Be sure to connect the terminal blocks to their designated location.

**Failure to follow these instructions will result in death or serious injury.**

**NOTE:** When installing the terminal blocks to the rear module, please keep the display module unmounted.

**NOTE:** To help prevent a terminal block from being inserted incorrectly, clearly and uniquely code and label each terminal block and rear module.

Avoid temperature changes on the thermocouple's connection terminal. Temperature measurements may not be accurate due to temperature changes in the cold junction (LT connection terminal for the thermocouple compensation cable).

The figure shows the labels on each terminal block:

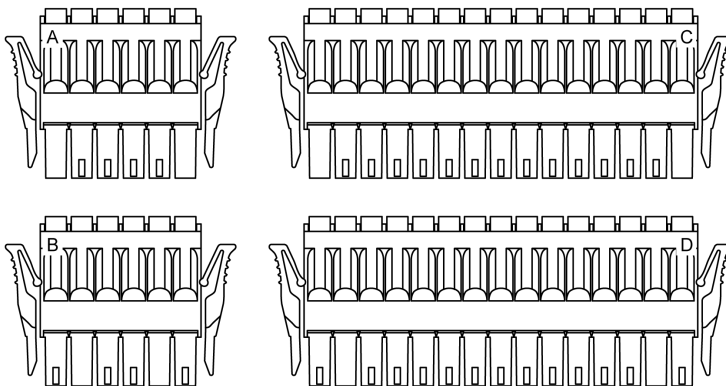

**NOTE:** Appearance of the connectors are the same but are different. Check the label and pin position of each connector before connecting.

**Protecting Outputs from Inductive Load Damage**

Depending on the load, a protection circuit may be needed for the outputs on the controllers and certain modules. Inductive loads using DC voltages may create voltage reflections resulting in overshoot that will damage or shorten the life of output devices.

**⚠ CAUTION**

**OUTPUT CIRCUIT DAMAGE DUE TO INDUCTIVE LOADS**

Use an appropriate external protective circuit or device to reduce the risk of inductive direct current load damage.

**Failure to follow these instructions can result in injury or equipment damage.**

Protective circuit A: this protection circuit can be used for DC load power circuits and source outputs (positive logic).

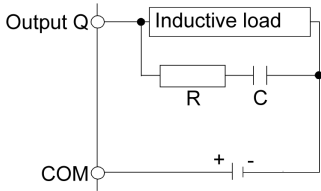

Protective circuit A: this protection circuit can be used for DC load power circuits and sink outputs (negative logic).

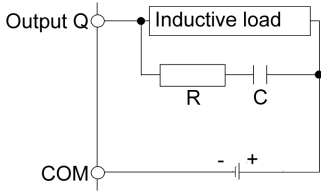

- C represents a value from 0.1 to 1  $\mu\text{F}$ .
- R represents a resistor of approximately the same resistance value as the load.

Protective circuit B: this protection circuit can be used for DC load power circuits and source outputs (positive logic).

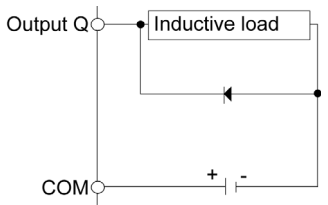

Protective circuit B: this protection circuit can be used for DC load power circuits and sink outputs (negative logic).

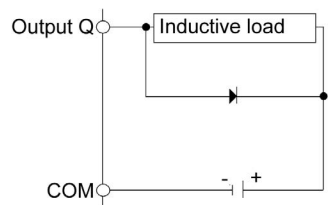



Use a diode with the following ratings:

- Reverse withstand voltage: power voltage of the load circuit x 10.
- Forward current: more than the load current.

Protective circuit C: this protection circuit can be used for DC load power circuits and source outputs (positive logic).

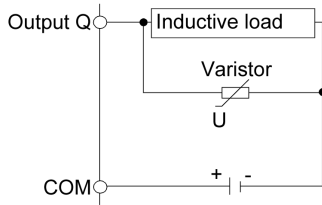

Protective circuit C: this protection circuit can be used for DC load power circuits and sink outputs (negative logic).

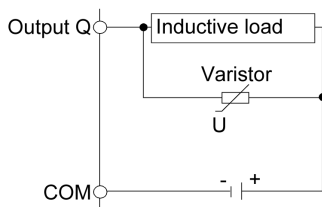

- In applications where the inductive load is switched on and off frequently and/or rapidly, ensure that the continuous energy rating (J) of the varistor exceeds the peak load energy by 20% or more.

## Wiring to the DIO Terminal Block

### Introduction

Wiring Rules and Recommendations.

⚠ CAUTION

**EQUIPMENT DAMAGE**

Be sure to remove the terminal blocks from the equipment prior to wiring.

**Failure to follow these instructions can result in injury or equipment damage.**

### Screwdriver Required to Wire Terminal Blocks

Recommended type: 1891348-1 (Tyco Electronics AMP)

If another manufacturer is used, be sure the part has the following dimensions:

- point depth: 1.5 mm (0.06 in.)
- point height: 2.4 mm (0.09 in.)

Point shape must be DIN5264A and meet standard DN EN60900.

Also, the screwdriver tip must be flat, as indicated, to access the narrow hole of the terminal block:

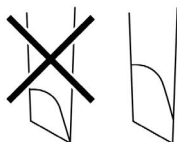

The terminal blocks are a spring clamp type.

### Procedure

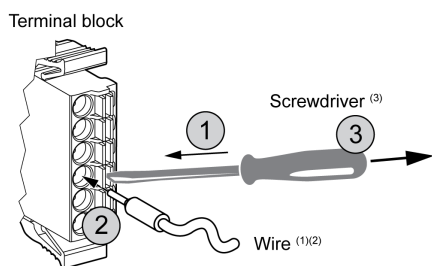

Use the following procedure to connect the wires to the terminal blocks:

Step	Action
1	Insert the screwdriver into the square-shaped hole. This will open the wire's round-shaped hole.
2	Hold the screwdriver and insert the wire into the wire's round-shaped hole.
3	Take out the screwdriver from the square-shaped hole. The round-shaped hole will then close, and the wire will be held securely in place.

**NOTE:** To remove the wire, reinsert the screwdriver into the square-shaped hole and when the wire's spring clamp releases, pull out the wire.

(1) Wire should be 0.20...0.81 mm<sup>2</sup> (AWG 24...18), with the end twisted. Applicable wire style are UL1015 and UL1007.

(2) Strip 7.0 mm (0.28 in) of jacket from the wire. Strip only the amount of jacket required. If too much jacket is removed, the ends may short against each other or against the terminals, which can create an electric short. If not enough jacket is removed, the wire may not make sufficient contact with the terminal.

Insert each wire completely into its opening. Improper insertion can lead to a loss of unit power or short circuit, either against the wire filaments or against the terminals, or to over heating of the wire and terminal.

(3) Do not rotate the point of the screwdriver inside the square-shaped opening. It may damage the equipment.

## **WARNING**

### **IMPROPER WIRING PRACTICES CAN MAKE EQUIPMENT INOPERABLE**

- Use only the specified wire sizes for I/O channels and power supplies.
- Prepare wires and make connections as specified in this documentation.
- Do not connect more than one wire per terminal block connector.

**Failure to follow these instructions can result in death, serious injury, or equipment damage.**

## Grounding the System

### Overview

To minimize the effects of electromagnetic interference, cables carrying the fast I/O, analog I/O, and Serial communication signals must be shielded.

### **WARNING**

#### **IMPROPER GROUNDING CAN CAUSE UNINTENDED EQUIPMENT OPERATION**

- Use cables with insulated shielded jackets for analog I/O, fast I/O and communication signals.
- Ground shielded cables for analog I/O, fast I/O and communication signals at a single point <sup>1</sup>.
- Always comply with local wiring requirements regarding grounding of cable shields.

**Failure to follow these instructions can result in death, serious injury, or equipment damage.**

<sup>1</sup>To avoid damage to the shielded cable when there is a short circuit in the power line, set up a multi-point frame ground (FG) each with the same electric potential.

The use of shielded cables requires compliance with the following wiring rules:

- When there is no protective earth ground, you can use metal conduit or cable duct shield as a part of the protective earth ground. The functional ground (FE) shield must attenuate electromagnetic interference and must be shielded the length of the cable. If the purpose is for both functional and protective grounding, as is often the case for communication cables, the cable must have continuous shielding.
- Wherever possible, keep cables carrying one type of signal separate from the cables carrying other types of signals or power.

### Protective Earth Ground on the Backplane

For protective grounding, connect braided copper cable (that can withstand the maximum voltage/current allowed by the system) to the conductive backplane.

### Functional Ground on the DIN Rail

The DIN rail for your LT is common with the functional ground plane and must be mounted on a conductive backplane.

### **WARNING**

#### **UNINTENDED EQUIPMENT OPERATION**

When connecting DIN rails, connect the DIN rails to functional ground (FE).

**Failure to follow these instructions can result in death, serious injury, or equipment damage.**

### Shielded Cables Connections

Cables carrying the fast I/O, analog I/O, and Serial communication signals must be shielded. The shielding must be securely connected to ground. The fast I/O and analog I/O shields may be connected either to the functional ground (FE) or to the protective earth ground (PE) of your LT.

**⚠ WARNING**

**ACCIDENTAL DISCONNECTION FROM PROTECTIVE GROUND (PE)**

- Do not use the grounding bar to provide a protective earth ground (PE).
- Use the grounding bar only to provide a functional ground (FE).

**Failure to follow these instructions can result in death, serious injury, or equipment damage.**

**⚠ DANGER**

**HAZARD OF ELECTRIC SHOCK**

Make sure that CANopen and Modbus cables are securely connected to the protective earth ground (PE).

**Failure to follow these instructions will result in death or serious injury.**

**NOTE:** The functional ground of the Ethernet connection is internal.

**Protective Earth Ground (PE) Cable Shielding**

The following shows the steps when using shield cables for grounding the LT power supply, Standard I/O, High-speed I/O, Analog I/O, Temperature Input, Communication cable so on.

Step	Description	
1	Strip the shielding for a length of 15 mm (0.59 in.)	<p>The diagram shows a cross-section of a shielded cable. The outer jacket is dark grey, and the inner insulation is light grey. A diagonal line indicates where the outer jacket has been stripped back. A dimension line above the stripped section shows a length of 15 mm, which is equivalent to 0.59 inches.</p>

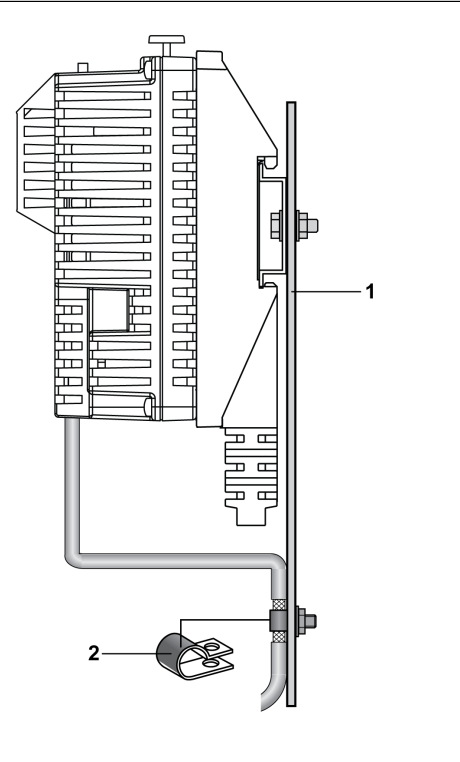
Step	Description
2	<p>Use the metal grounding clamp(2) to attach the cable to the backplane plate (1) as close as possible to the LT.</p> 

**NOTE:** The shielding must be clamped securely to the conductive backplane to ensure a good contact.

**Exclusive Grounding**

Connect the frame ground (FG) terminal on the power plug to an exclusive ground. When supplying power to the LT unit, be sure to separate the input, output and power lines, as shown:

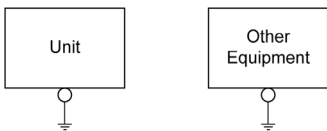

**Common Grounding**

If exclusive grounding is not possible, use a common grounding point. Use grounding resistance of 10 Ω or less, wire thickness of 2.6 mm or more, or your country's applicable standard for the grounding point.

Precautions:

- Do not use common grounding, since it can lead to accidents and machine breakdown.
- If the equipment does not function properly when grounded, disconnect the ground wire from the FG terminal.

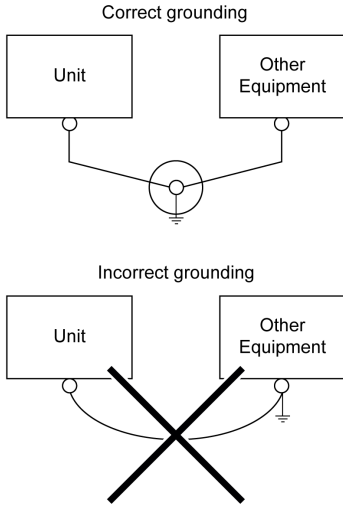

### Grounding Procedure

Step	Action
1	Check that the grounding resistance is less than 100 $\Omega$ . (Grounding resistance of 100 $\Omega$ or less, wire thickness of 1.6 mm or more, or your country's applicable standard.)
2	Create the connection point as close to the unit as possible, and make the wire as short as possible. When using a long grounding wire, replace the thin wire with a thicker wire, and place it in a duct.

**NOTE:** FG and SG terminals are internally connected in the LT. When connecting an external device to the LT using the SG terminal, be sure to check that no short-circuit loop is created when you setup the system.





---

# Chapter 3

## LT Description

---

### Overview

This chapter describes the LT features.

### What Is in This Chapter?

This chapter contains the following sections:

Section	Topic	Page
3.1	Rear Module Features	42
3.2	I/O Management	43

## Section 3.1

### Rear Module Features

---

#### Clock

##### Overview

The LT has a clock.

Variations in operating conditions can cause a clock shift:

Ambient Temperature	Accuracy (30 days deviation)
0 °C (32 °F)	-2.5...2.5 minutes
25 °C (77 °F)	-2.5...2.5 minutes
50 °C (122 °F)	-5.5...2.5 minutes

##### Battery for Clock

The controller has one battery for the clock.

In the event of a power interruption, the backup battery retains the time and date for the controller.

The table describes the characteristics of the battery:

<b>Use</b>	In the event of a transient power outage, the battery powers the clock.
<b>Duration of backup</b>	At least 5 years at 25 °C max (77 °F). At higher temperatures, the duration of backup is reduced.

**NOTE:** Do not replace the LT unit's battery yourself. The LT uses a lithium battery for backing up its internal clock data and the battery may explode if it is replaced incorrectly. When replacement is required, please contact your local LT distributor.

---

## Section 3.2

### I/O Management

---

#### What Is in This Section?

This section contains the following topics:

Topic	Page
Input Management	44
Output Management	45

## Input Management

### Overview

LT is equipped with Standard Inputs and Fast Inputs. You can manage the input values using the software filter function that eliminates the input signal noise.

This section explains the filter concept using Fast Input as an example. High-speed Counter Input and Pulse Catch Input can be managed as Special Input and Output.

### Filter Principle of Special I/O

The filter is designed to reduce the bouncing effect at the inputs. Setting a filter value allows the controller to ignore sudden changes of input levels caused by noise.

The following timing diagram illustrates the filter effects:

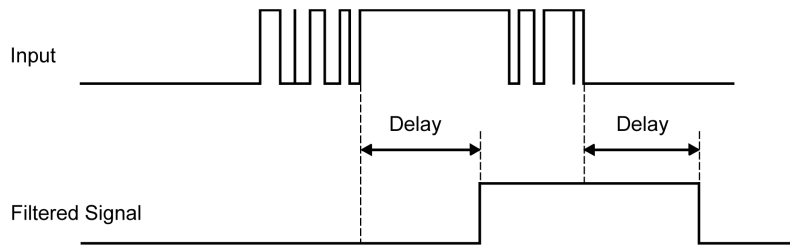

## Output Management

### Introduction

The LT Unit includes Standard outputs and fast outputs.

The following output functions are configurable on fast outputs:

- PWM output
- Pulse output
- High-speed Counter (Synchronize Output)

### Fast Output Management Availability

The information refers to all LT with fast outputs:

Output Terminal	Function
Q0	Pulse Output/CH 0, PWM Output/CH 0, High-speed Counter (Synchronize Output)/CH 0
Q1	Pulse Output/CH 1, PWM Output/CH 1 High-speed Counter (Synchronize Output)/CH 1

### Short-circuit or Over-Current on Outputs

There are two groups for the output's short circuit and over-current.

Group 1 (Fast Output) has a short-circuit protection circuit between the output and V-. Group 2 (Standard Output) does not have this circuit.

LT-4201TM (Modular Type DIO) and LT-4301TM (Modular Type DIO):

- Group 1: 2 points Fast Outputs (Q0 to Q1)
- Group 2: 10 points Standard Outputs (Q2 to Q11)

LT-4201TM (Modular Type Analog) and LT-4301TM (Modular Type Analog):

- Group 1: 2 points Fast Outputs (Q0 to Q1)
- Group 2: 6 points Standard Outputs (Q2 to Q7)

The table describes the errors:

If...	then...
you have a short-circuit at 0 V on Fast Output	Fast Output is stopped and error message is generated. For more details, refer to the GP-Pro EX Reference Manual.
you have a short-circuit at 24 V on Fast Output	
the current crossing the Fast Output is too high	

For more information on protecting outputs, refer to your controller wiring diagram and to the general wiring rules (see page 30).

The Standard outputs of this equipment do not have built-in reverse polarity protection. Incorrectly connecting polarity can permanently damage the output circuits or otherwise result in unintended operation of the equipment.

## **NOTICE**

### **DAMAGE TO FAST OUTPUTS**

- Ensure the use of adequate protection against short-circuits on the power supply to the fast outputs.
- Do not connect positive voltage to any of the DC fast outputs terminals.

**Failure to follow these instructions can result in equipment damage.**

** WARNING**

**UNINTENDED MACHINE START-UP**

Inhibit the automatic rearming of outputs if this feature is an undesirable behavior for your machine or process.

**Failure to follow these instructions can result in death, serious injury, or equipment damage.**

**Wiring Considerations**

**NOTE:** Turn on the power of LT before turning on the power of external I/O. Otherwise, the wrong signal for Pulse Output, PWM Output and High-speed Counter (Synchronize Output) is output.

** WARNING**

**UNINTENDED EQUIPMENT OPERATION**

Be sure to wire the outputs correctly according to the wiring diagram.

**Failure to follow these instructions can result in death, serious injury, or equipment damage.**

---

# Chapter 4

## Device Connectivity

---

### Introduction

This chapter presents the equipment you can connect to the LT panel.

### What Is in This Chapter?

This chapter contains the following topics:

Topic	Page
System Design	48
Interface Accessories	51

---

## System Design

### Introduction

The following diagrams represent the main selection of equipment you can connect to the panels.

### Edit Mode Peripherals

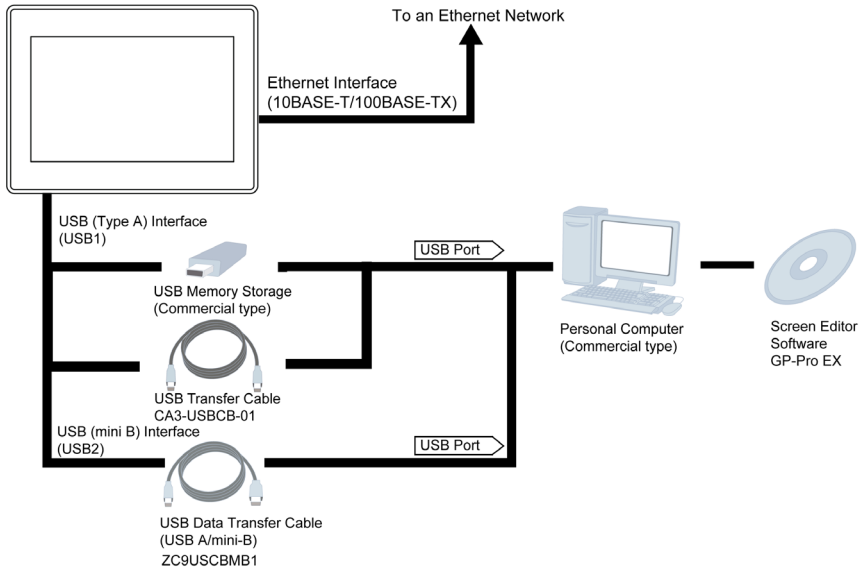



**Run Mode Peripherals - USB Type A/Mini B Interface**

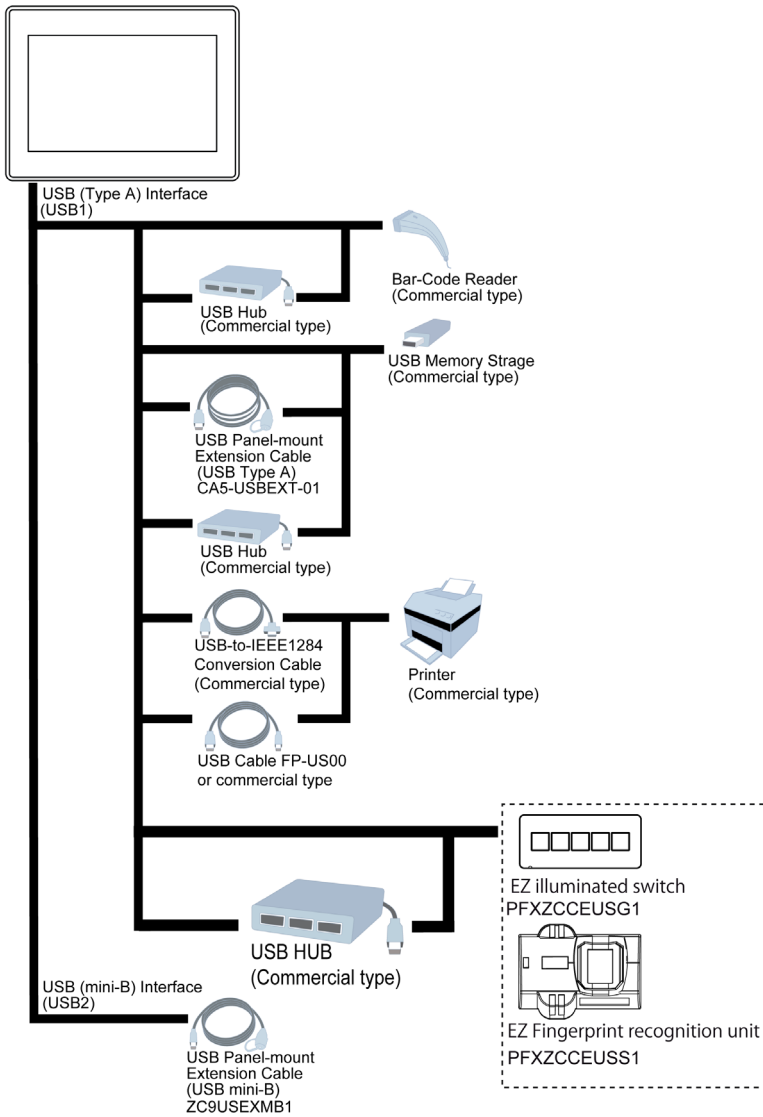

**Run Mode Peripherals - Serial Communication and Ethernet Communication**

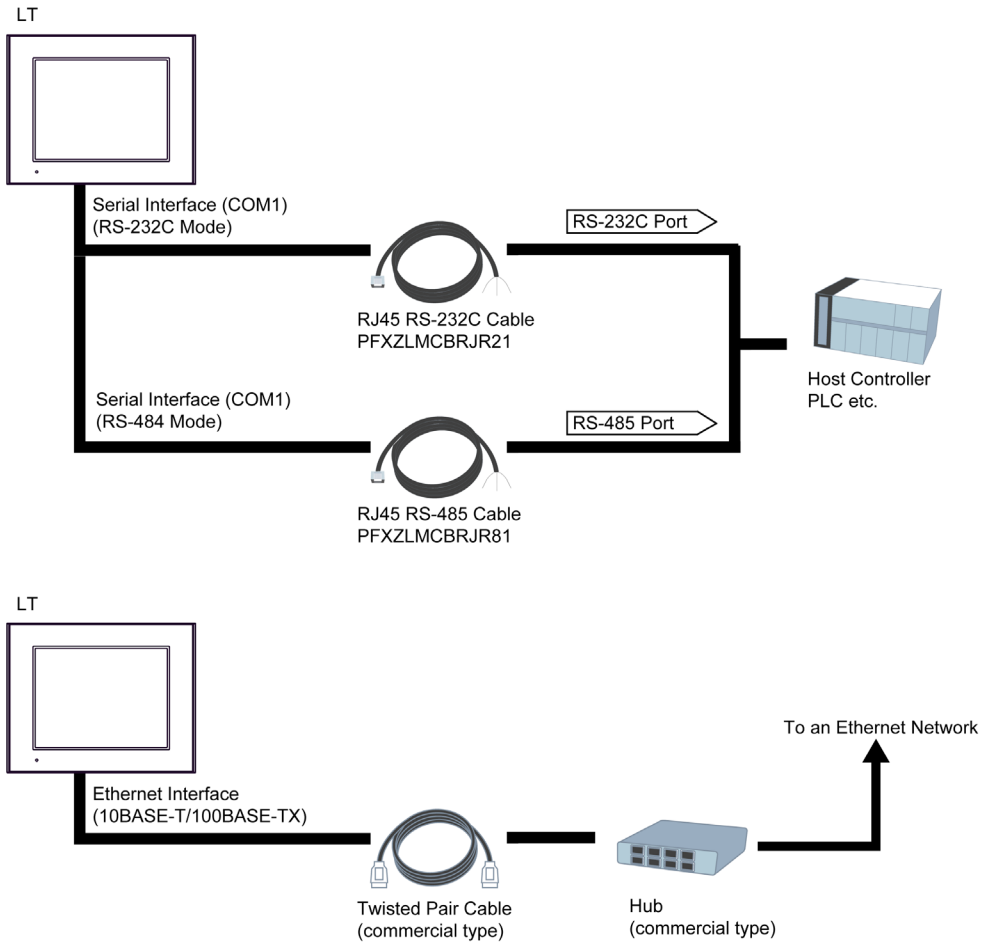

## Interface Accessories

### Serial Interface Items

Reference Name	Reference Number	Description
RJ45 RS-232C cable (5 m)	PFXZLMCBRJ21	Cable with loose wires at one end for RS-232C connection between various hosts and the LT
RJ45 RS-485 cable (5 m)	PFXZLMCBRJ81	Cable with loose wires at one end for RS-485 connection between various hosts and the LT

### USB Host Interface

Reference Name	Reference Number	Description
USB transfer cable (2 m)	CA3 USBCB-01	Download project data created with the Screen Editor and Logic Program Software via the LT unit's USB I/F.
USB cable (5 m)	FP-US00	Connects a USB printer (type B)
USB front cable (1 m)	CA5 USBEXT-01	Extension cable that attaches to USB (mini B) port of the LT
USB transfer cable (USB A/mini B) (1.8 m)	ZC9USCBMB1	Cable for transferring screen data from the PC (USB type A) to LT (USB mini B)
USB panel-Mount extension cable (USB mini B) (1 m)	ZC9USEXMB1	Extension cable that attaches to USB (mini B) port of the LT
EZ illuminated switch	PFXZCCEUSG1	A unit of 5 illuminated switches with multiple color LED easily connected with LT via USB
EZ fingerprint recognition unit	PFXZCCEUSS1	Fingerprint recognition unit easily connected with LT via USB
EZ numpad	PFXZCCEUKB1	Numpad easily connected with LT via USB
EZ Tower Light tube mounting with fixing plate	PFXZCETWHA1	USB connection type monolithic EZ tower light tube mounting with fixing plate 3 tiers, Ø60, lighting and flashing with a buzzer
EZ Tower Light with base mounting	PFXZCETWW1	USB connection type monolithic EZ tower with base mounting 3 tiers, Ø60, lighting and flashing with a buzzer

### Software

Reference Name	Description
GP-Pro EX	GP-Pro EX is screen editing & logic programming software made by Digital Electronics Corporation. You can edit screens with simple operations.

### Maintenance Options

Reference Name	Reference Number	Description
Installation nut	PFXZGMNT1	Nut to install the display module (10 pcs/set).
Socket wrench	PFXZGMSW1	Socket wrench to tighten and loosen the display installation nut.

Reference Name	Reference Number	Description
Accessories kit	PFXZGMAK1	Anti-rotation tee, USB cable clamp to prevent disconnection (Type A, mini-B, for 1 port), 2 mm-high spacer to adjust installation panel thickness (1pcs/each).
DC power supply connector	PFXZGMCNDC1	Connector to connect DC power supply cable (5 pcs/set).
DIO connector for LT4000M	PFXZLMCNIO1	15-pin I/O connector (Connector A x 1, Connector B x 1) and 6-pin I/O connector (Connector C x 1, Connector D x 1). <b>NOTE:</b> Connector A and B are different and connector C and D are different.

### Options Items

Reference Name	Reference Number	Description
Screen protection sheet	LT-4201TM: CA6-DFS4-01	Disposable, dirt-resistant sheet for the unit' screen (5 sheet/set) (hard type).
	LT-4301TM: PFXZCBDS61	
Display module/Rear module separation cable	PFXZXMADSM31	Cable with hook to install a rear module on a DIN rail while connecting the rear module to a separated display module 3 m/5 m.
	PFXZXMADSM51	
Rear module installation adapter	PFXZXMADSA1	DIN rail installation adapter for rear modules in non-display operation.

### CANopen Cables and Connectors Parts

	Reference Number	Manufacturer	Description
Recommended cable connector	XM2D-0901	OMRON Co.	DSUB 9-pin socket
	TSXCANKCDF180T	Schneider Electric	Straight connector with terminal selector switch.
	VS-09-BU-DSUB/CAN	PHOENIX CONTACT	Connector with terminal block and terminal selector switch
	SUBCON-PLUS-CAN/AX	PHOENIX CONTACT	Straight connector with terminal selector switch
CANopen recommended transfer cable	TSXCAN CA50 TSXCAN CA100	Schneider Electric	Cable for CANopen (IEC60332-1) 50 m/100 m.
	TSXCAN CB50 TSXCAN CB100	Schneider Electric	UL-approved cable for CANopen (IEC60332-2) 50 m/100 m.

---

# Chapter 5

## LT Installation

---

### Overview

This chapter provides installation safety guidelines, device dimensions, mounting instructions, and environmental specifications.

### What Is in This Chapter?

This chapter contains the following sections:

Section	Topic	Page
5.1	Mechanical Requirements	54
5.2	Electrical Requirements	75
5.3	USB Port	82

# Section 5.1

## Mechanical Requirements

---

### What Is in This Section?

This section contains the following topics:

Topic	Page
Display Module and Rear Module Dimensions	55
Rear Module Dimensions	58
Separation Cable Dimensions	59
Panel Cut-Out Dimensions and Installation	60
Installation Procedures	63
Mounting Positions	68
Mounting Clearances	69
DIN Rail	71
Installing and Removing the Rear Module on a DIN Rail	72

## Display Module and Rear Module Dimensions

### 3.5 Inches Display Module

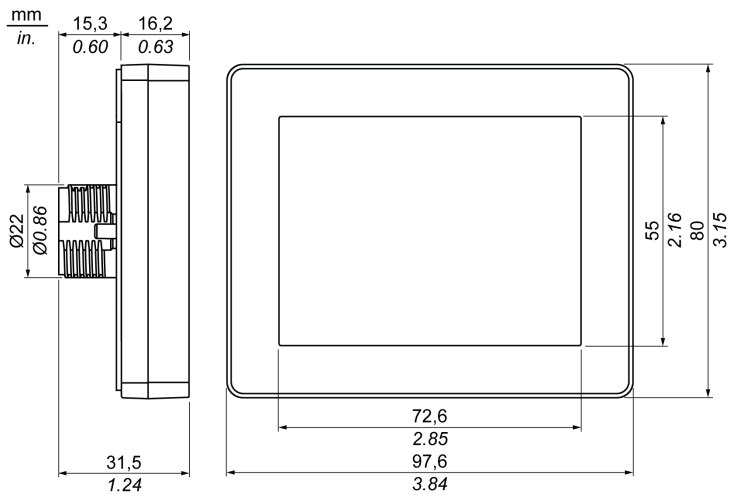

### 5.7 Inches Display Module

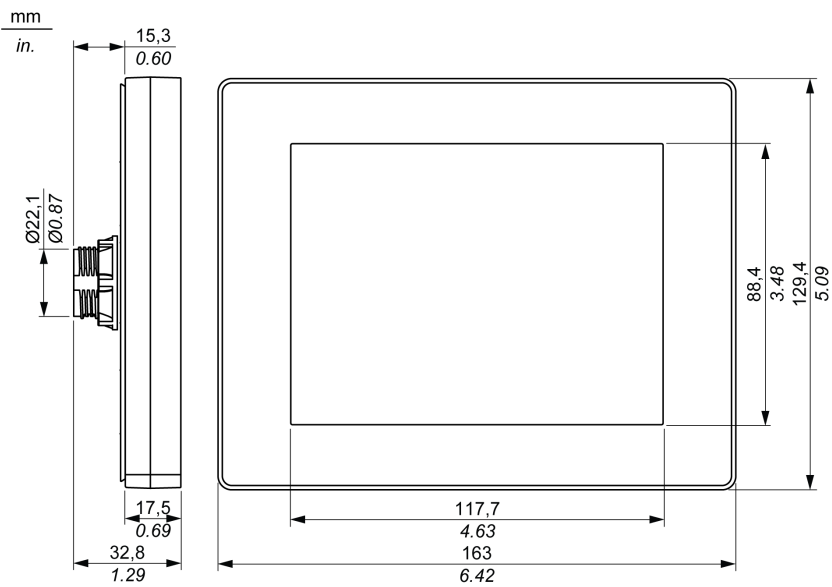

**Rear Module**

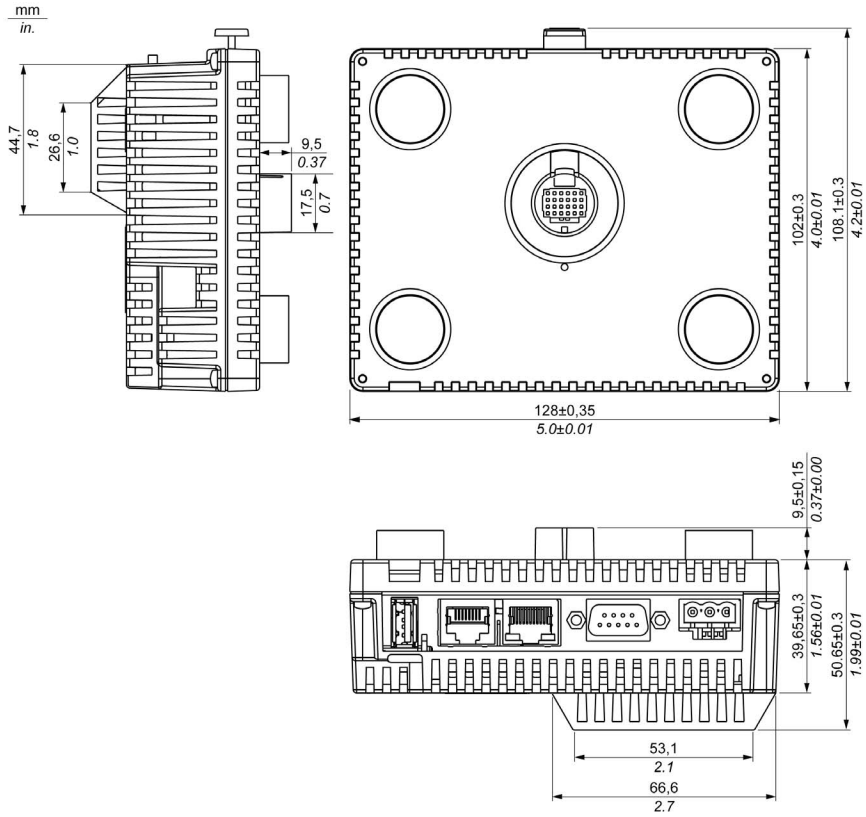

**3.5 Inches Display Module and Rear Module**

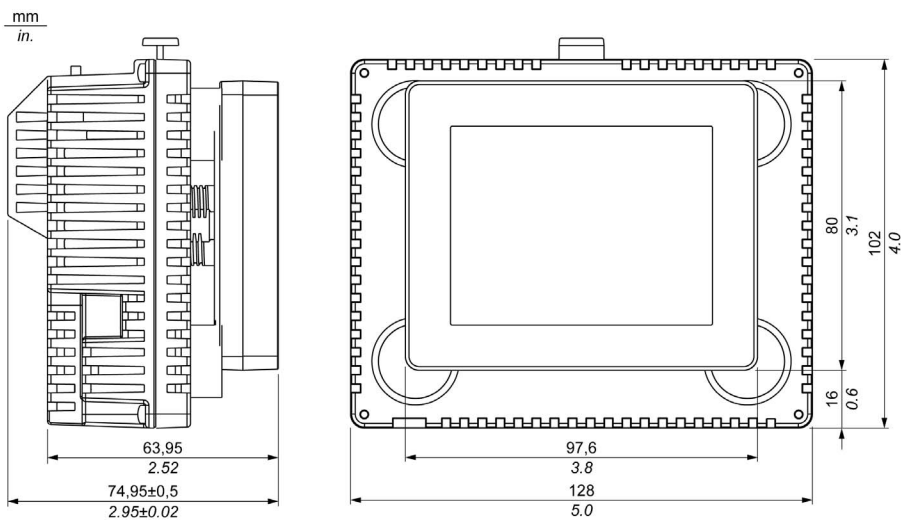



**5.7 Inches Display Module and Rear Module**

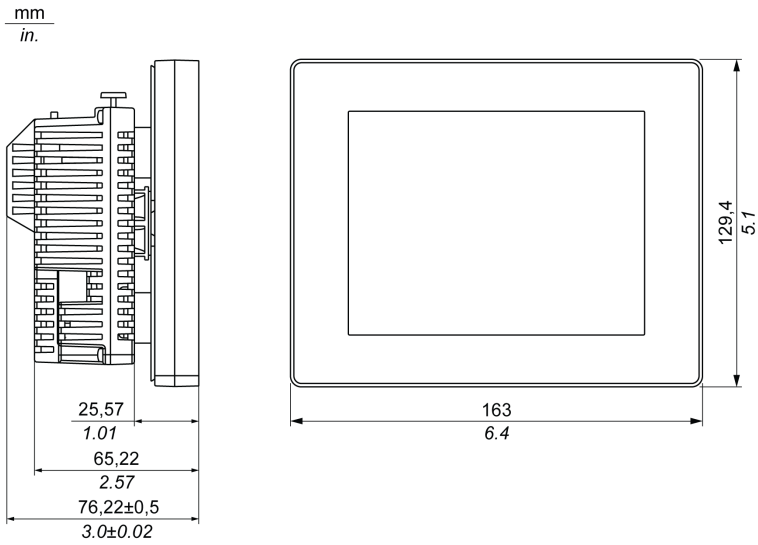

# Rear Module Dimensions

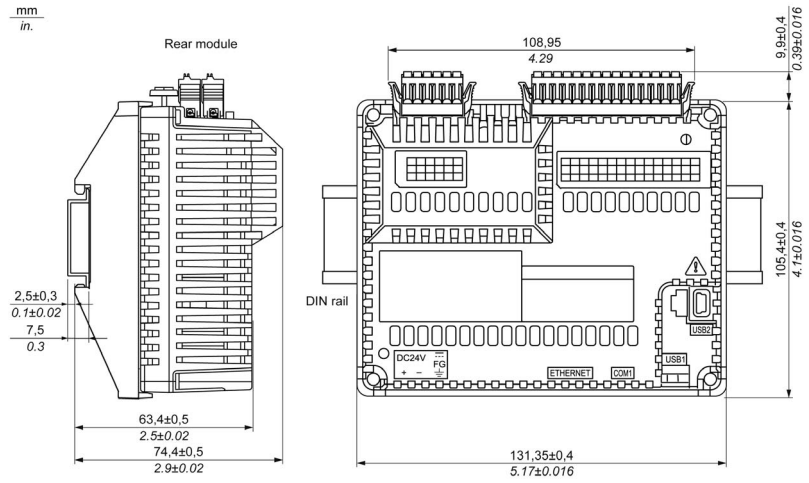

## Separation Cable Dimensions

### Display Module/Rear Module Separation Cable

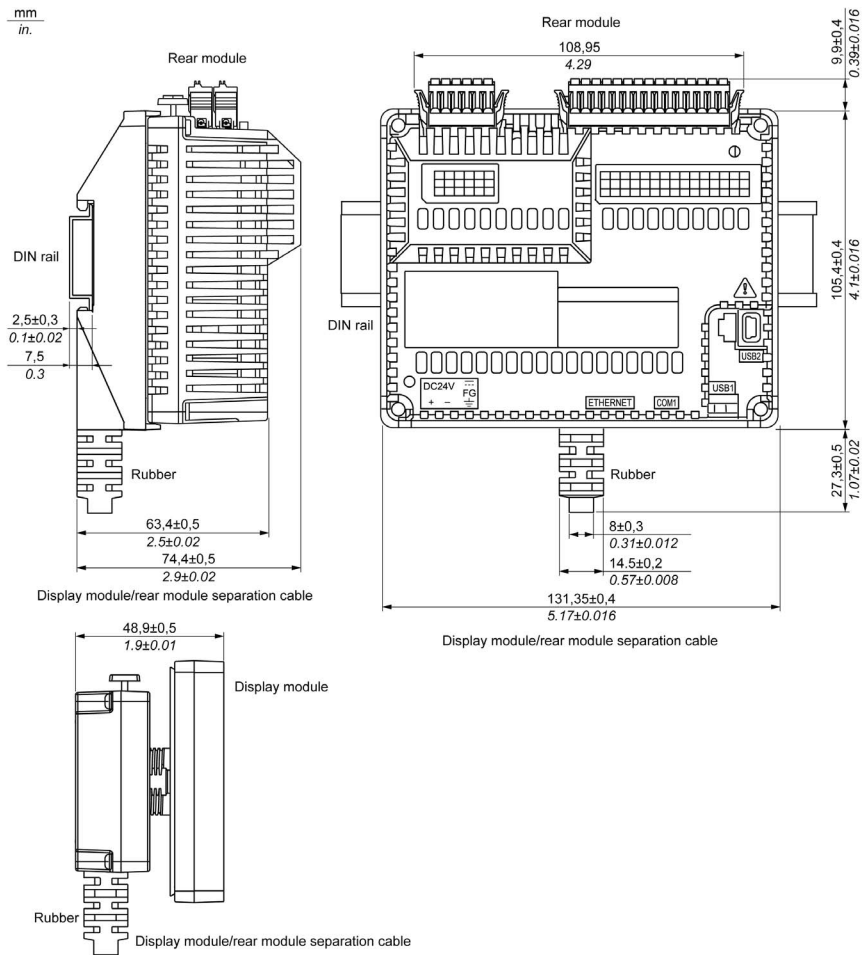

**NOTE:**

Use this display module/rear module separation cable when the rear module is installed on a DIN rail:

- The outer diameter of the cable is 8 mm (0.31 in.).
- There are 2 types of cable: 3 m (9.84 ft) and 5 m (16.4 ft).
- To assemble this product, you need 20 mm (0.78 in.) more space to bend the cable in the end of the rubber.

## Panel Cut-Out Dimensions and Installation

### Inserting a Display Module Without an Anti-Rotation Tee

Create a panel cut-out and insert the display module into the panel from the front.

The figure shows the panel cut-out:

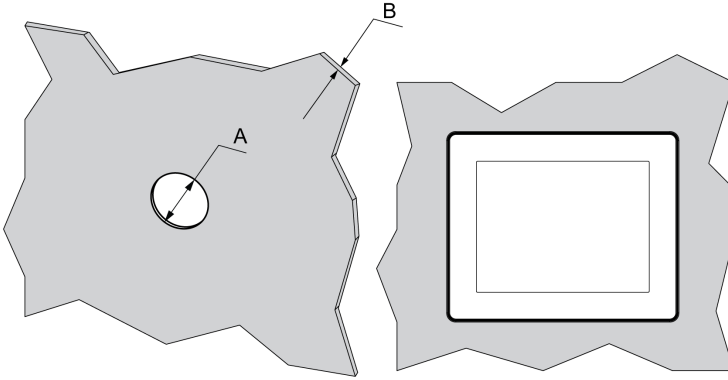

### Dimensions

A	B (1)	B (2)
22.50 <sup>0/-0.30</sup> mm (0.88 <sup>0/-0.01</sup> in.)	1.5...6 mm (0.06...0.23 in.)	3...6 mm (0.11...0.23 in.)
(1) Steel sheet		
(2) Glass fiber reinforced plastics (minimum GF30)		

**NOTE:** Without the tee option, the display module supports a rotating torque of 2.5 N•m (22.12 lb-in).

### Inserting a Display Module With an Anti-Rotation Tee

Create a panel cut-out and insert the display module into the panel from the front.

The figure shows the panel cut-out for a LT Unit using a tee:

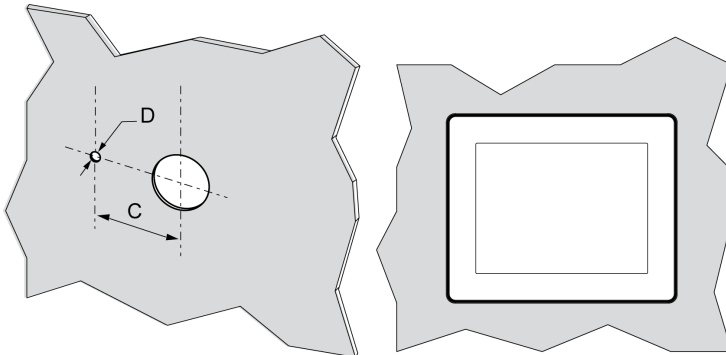

## Dimensions

C	D
30 <sup>0/-0.20</sup> mm (1.18 <sup>0/-0.0007</sup> in.)	4 <sup>0/-0.20</sup> mm (0.15 <sup>0/-0.007</sup> in.)

**NOTE:** With the tee option, the display module supports a rotating torque of 6 N•m (53.10 lb-in).

## Installing the LT Display

The figure shows the assembly:

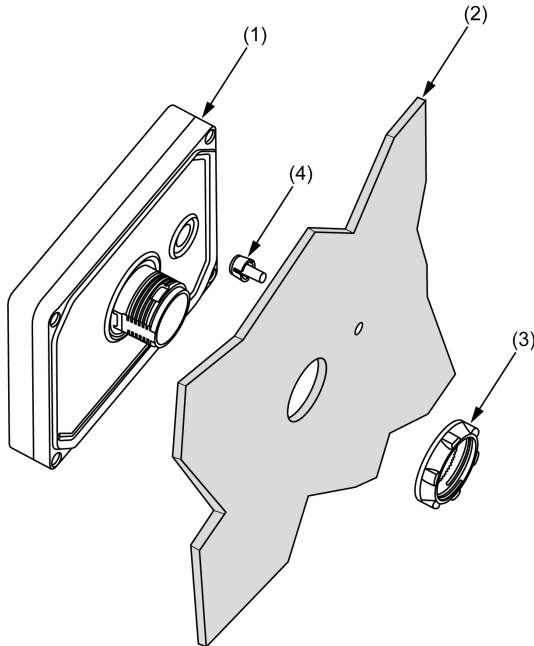

- (1) Display module
- (2) Panel
- (3) Display installation nut
- (4) Anti-rotation tee

## Installing the LT Display Module with Spacer

The spacer supplied in the accessory kit PFXZGMAK1 (sold separately), allows mounting the product on a:

- steel sheet support with a thickness between 1 and 1.5 mm (0.039 in. and 0.059 in.)
- plastic support with a thickness between 1 and 3 mm (0.039 in. and 0.118 in.)
- glass fiber reinforced plastic with a thickness between 2 and 3 mm (0.078 in. and 0.118 in.)

The figure shows the assembly with the Panel spacer:

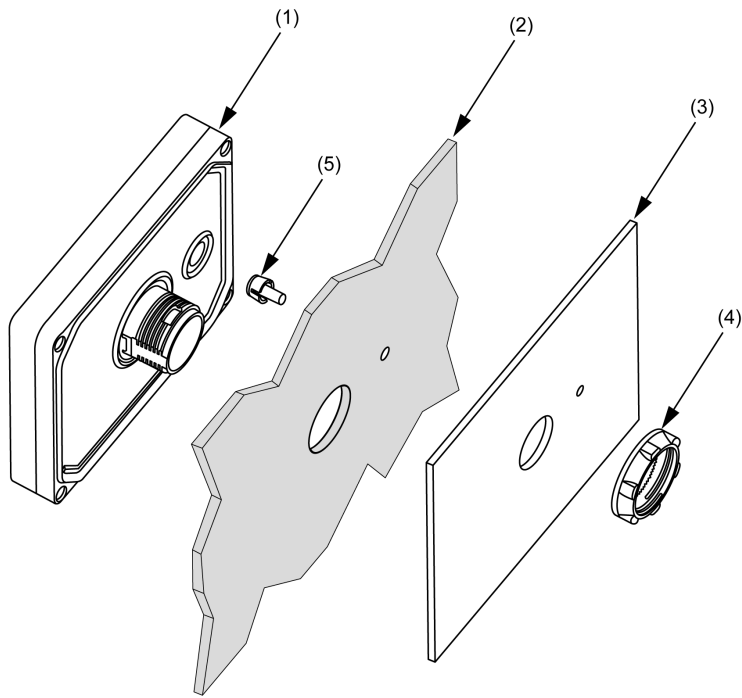

- (1) Display module
- (2) Panel
- (3) Spacer
- (4) Display installation nut
- (5) Anti-rotation tee

## Installation Procedures

### Installing the LT Unit

In order to correctly run an application on the LT, both the display module and the rear module must be connected.

### **⚠ WARNING**

#### **EXPLOSION HAZARD**

- Do not connect or disconnect while circuit is live.
- Potential electrostatic charging hazard: wipe the front panel of the terminal with a damp cloth before turning ON.

**Failure to follow these instructions can result in death, serious injury, or equipment damage.**

If you power up the rear module without connecting the display module, the logic controller does not start and all outputs remain in the initial state. The power must be off before connecting the modules.

There are 2 ways to install the LT.

Installing the LT on the panel:

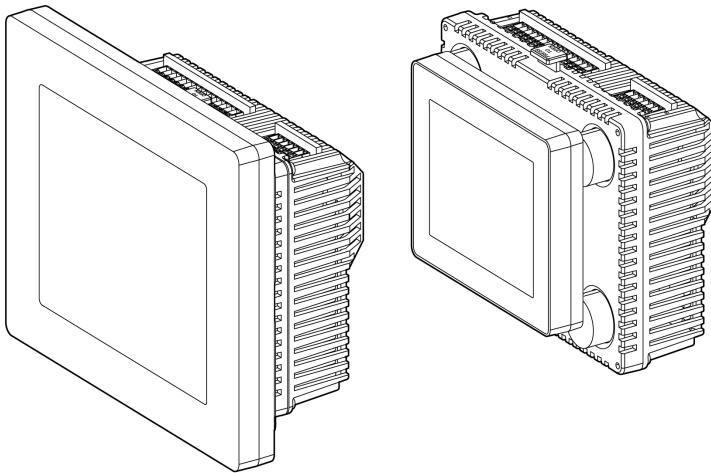

Installing the rear module on a DIN rail with a display module/rear module separation cable:

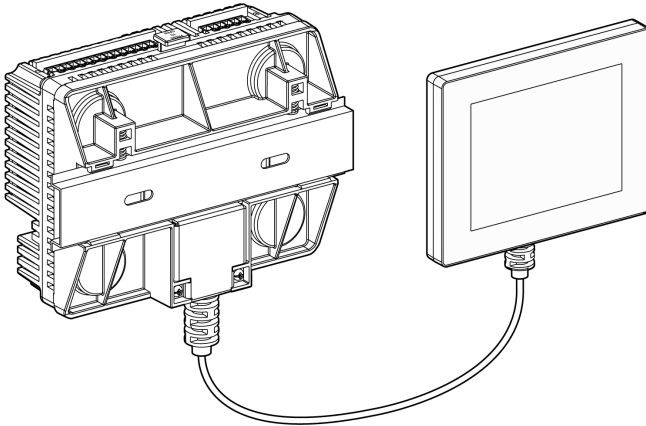

### LT Setup Procedure

Mount the unit in an enclosure that provides a clean, dry, robust, and controlled environment (IP65 enclosure or UL508 4x, if indoors).

Before installing the LT verify that:

- The installation panel or cabinet surface is flat (planarity tolerance: 0.5 mm (0.019 in.)), in good condition and has no jagged edges. Metal reinforcing strips may be attached to the inside of the panel, near the panel cut-out, to increase the rigidity.
- The panel is designed to avoid any induced vibration resonance on the rear module exceeding a punctual factor of 10 and avoids any induced permanent vibration resonance. To reduce the resonance use the panel adaptor accessory.
- The ambient operating temperature and the ambient humidity are within their specified ranges. (When installing the panel in a cabinet or enclosure, the ambient operation temperature is the internal temperature of the cabinet or enclosure).
- The heat from surrounding equipment does not cause the unit to exceed its specified operating temperature.
- When installing the display module in a vertical position (portrait view), the logo on the display face must be on the right side to keep the power connector at the top:

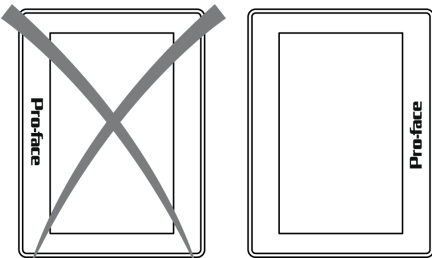

**NOTE:** For use in Pollution Degree 2 environments.



- The panel face is not inclined more than 30° when installing the unit in a slanted panel:

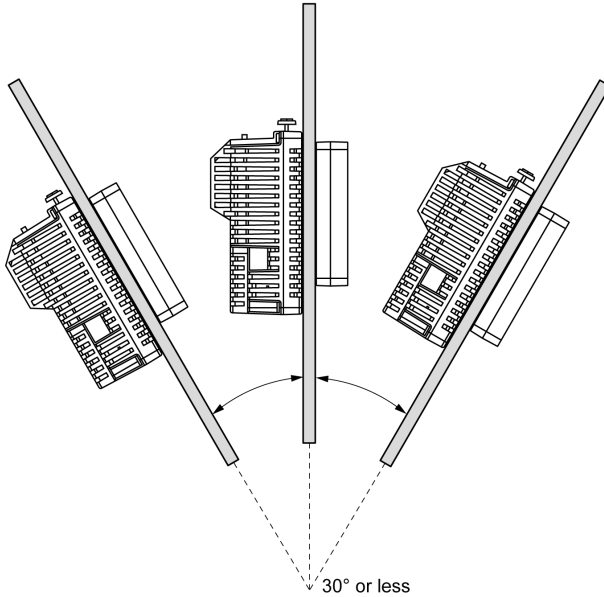

- The power plug is positioned vertically when the unit is vertically installed.
- The unit is at least 100 mm (3.94 in.) away from adjacent structures and other equipment for easier maintenance, operation, and improved ventilation:

mm  
in.

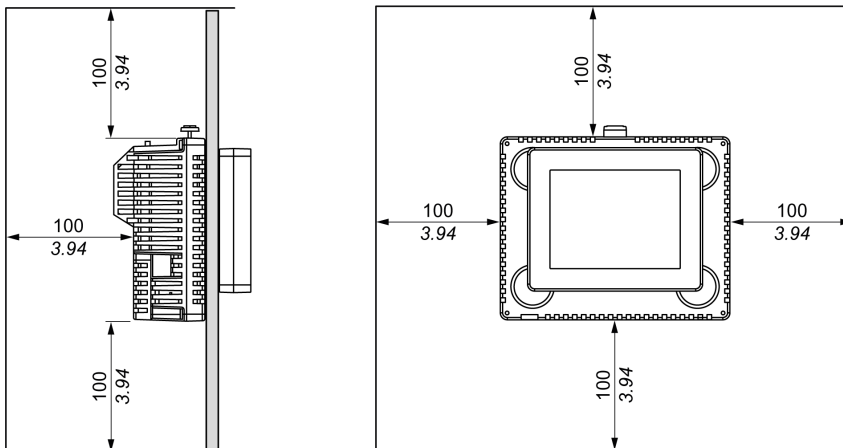

Step	Action
1	Place the unit on a clean and level surface with the display panel facing downward.
2	<p>The support thickness depends on the material:</p> <ul style="list-style-type: none"> <li>• Steel sheet: between 1.5 and 6 mm (0.059 in. and 0.236 in.)</li> <li>• Plastic: between 3 and 6 mm (0.118 in. and 0.236 in.)</li> </ul> <p>If the thickness is between 1 and 1.5 mm (0.039 in. and 0.059 in.) for a steel sheet support or between 1 mm and 3 mm (0.039 in. and 0.118 in.) for plastic, use the spacer adaptor supplied in accessory kit PFXZGMAK1 (sold separately).</p>

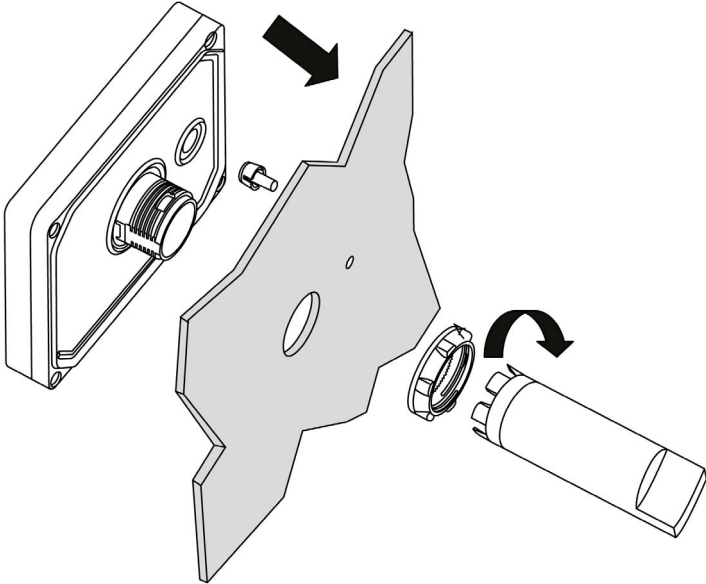
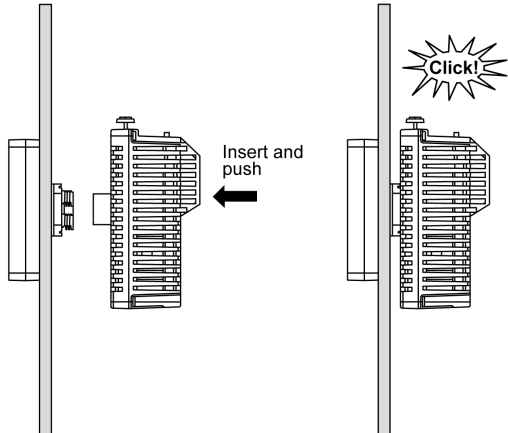
Step	Action
3	Create the correct sized holes required to install the unit, using the Panel Cut-Out Dimension and Installation.
4	<p data-bbox="319 266 980 291">Insert the display module (with the tee, if required) into the panel hole:</p>  <p data-bbox="319 942 1060 993">Use a torque between 1.2 and 2 N•m (10.62 lb-in and 17.70 lb-in) to screw the nut with the tightening wrench.</p>
5	<p data-bbox="319 1008 843 1033">Insert and push the rear module until it locks into place:</p> 

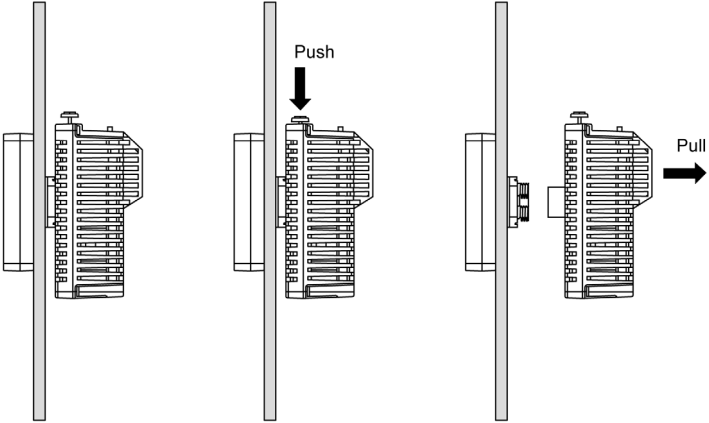
Step	Action
6	<p>To remove the rear module, push the yellow button to unlock it, and then pull out the rear module:</p>  <p style="text-align: center;"> <span data-bbox="395 716 454 736">Locked</span> <span data-bbox="614 716 687 736">Unlocked</span> <span data-bbox="920 716 961 736">Free</span> </p>

## ***NOTICE***

### **EQUIPMENT DAMAGE**

Be sure to remove the rear module from the display module without twisting.

**Failure to follow these instructions can result in equipment damage.**

## Mounting Positions

### Correct Mounting Position

The rear module must be mounted with steel sheet horizontally or vertically plane as shown in the figure:

Horizontal Mounting

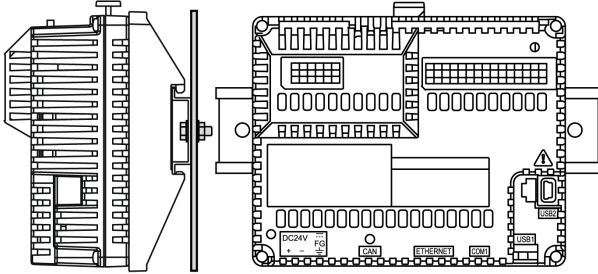

Vertical Mounting

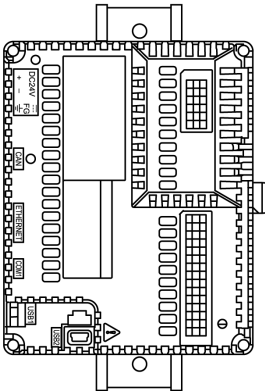

**NOTE:** Keep adequate spacing for proper ventilation to maintain an ambient temperature between 0...50 °C (32...122 °F) for horizontal installation and 0...40 °C (32...104 °F) for vertical installation.

### Incorrect Mounting Position

The rear module should only be positioned as shown in the Correct Mounting Position figure to help ensure adequate air flow through the product.

The figures show incorrect mounting positions:

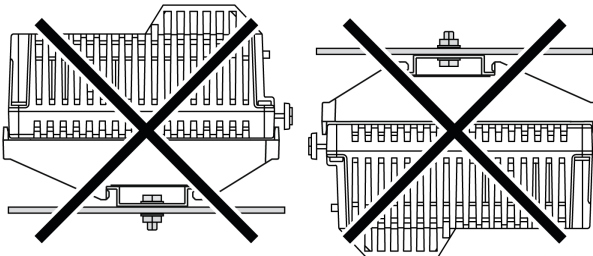

## Mounting Clearances

### **WARNING**

#### **UNINTENDED EQUIPMENT OPERATION**

- Place devices dissipating the most heat at the top of the cabinet and ensure adequate ventilation.
- Avoid placing this equipment next to or above devices that might cause overheating.
- Install the equipment in a location providing the minimum clearances from all adjacent structures and equipment as directed in this document.
- Install all equipment in accordance with the specifications in the related documentation.

**Failure to follow these instructions can result in death, serious injury, or equipment damage.**

**NOTE:** Keep adequate spacing for proper ventilation to maintain an ambient temperature between 0...50 °C (32...122 °F) for horizontal installation and 0...40 °C (32...104 °F) for vertical installation.

### **Mounting and Keeping LT Ventilated**

The rear module has been designed as an IP20 product and must be installed in an enclosure.

The clearances must be respected when installing the product:

- Distance and separation between the rear module and the front installation panel.
- Distance and separation between the rear module and wiring ducts.
- Distance and separation between the rear module and peripherals.

The figure shows the minimum clearances for the LT controller:

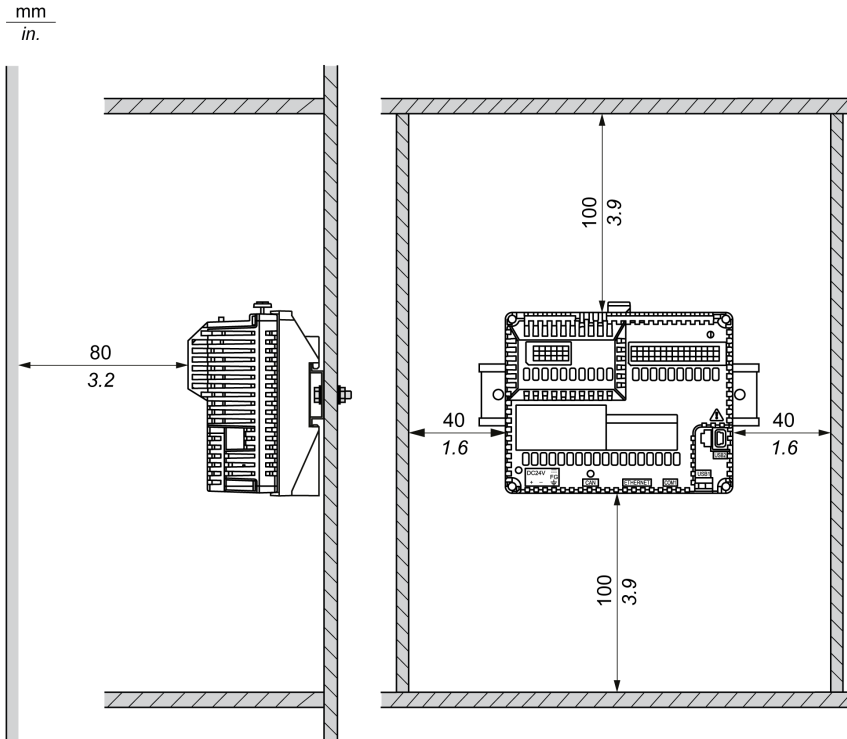

## DIN Rail

### Dimensions of the DIN Rail

You can mount the controller and its expansion parts on a DIN rail. A DIN rail can be attached to a smooth mounting surface or suspended from a EIA rack or a NEMA cabinet.

The DIN rail measures 35 mm (*1.38 in.*) high and 15 mm (*0.59 in.*) deep, as shown below:

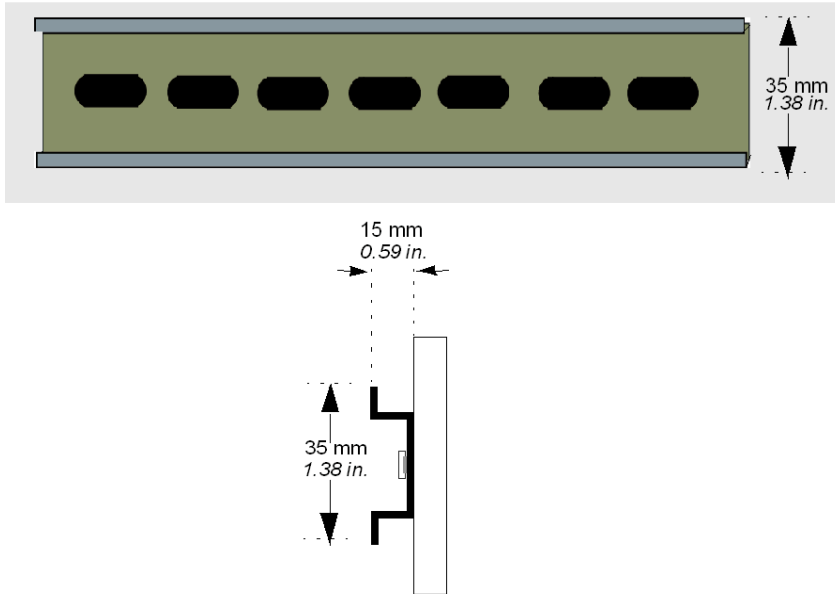

## Installing and Removing the Rear Module on a DIN Rail

### Overview

This section describes how to install and remove the rear module on a DIN rail:

Reference Name	Reference Number
Display Module/Rear Module Separation Cable	PFXZXMADSM31
	PFXZXMADSM51
DIN rail installation adapter	PFXZXMADSA1

**NOTE:** Attach front module and rear module both when you use a display module/rear module separation cable.

If the rear module is powered without it being directly connected (or connected with a separation cable) to the display module, the PLC Logic goes into the STOP mode with I/Os in a fallback mode.

### ⚠ WARNING

#### EXPLOSION HAZARD

- Do not connect or disconnect while circuit is live.
- Potential electrostatic charging hazard: wipe the front panel of the terminal with a damp cloth before turning ON.

**Failure to follow these instructions can result in death, serious injury, or equipment damage.**

### Installing the Rear Module on a DIN Rail

The procedure describes how to install the rear module on a DIN rail:

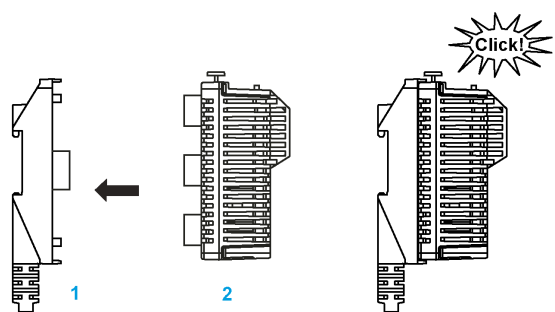
Step	Action
1	Using screws to fasten the DIN rail to a panel surfaces.
2	Affix the display module/rear module separation cable or the rear module installation adapter to the rear module.   <p>1 Display module/rear module separation cable 2 Rear module</p> <p><b>NOTE:</b> To assemble this product, you need 20 mm (0.78 in.) more space to bend the cable in the end of the rubber (see page 20).</p>



Step	Action
<p>3</p>	<p>Position the top groove of the rear module on the top edge of the DIN rail and press the assembly against the DIN rail until you hear the DIN rail clip click into place.</p> <p>mm in.</p> <p>AM1DE200 IEC/EN 60715</p> <p>AM1DP200</p> <p>AM1ED200</p> <p>1 Rear module 2 Rail</p> <p><b>NOTE:</b> A terminal block end clamps help minimize sideways movement and improve the shock and vibration characteristics of the controller assembly.</p>
<p>4</p>	<p>Install the display on the cabinet and affix the display module/rear module separation cable to the display.</p> <p>1 Display module 2 Display module/rear module separation cable</p>

### Removing the Rear Module from a DIN Rail

The following procedure describes how to remove the rear module from a DIN rail:

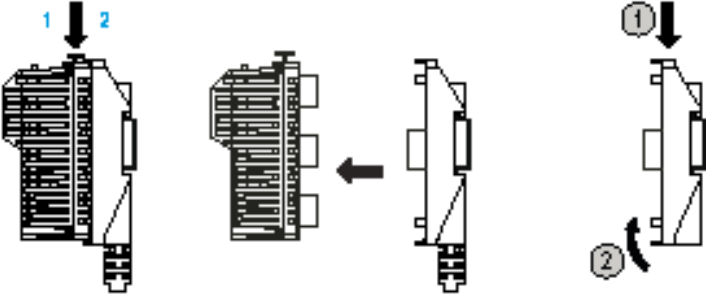
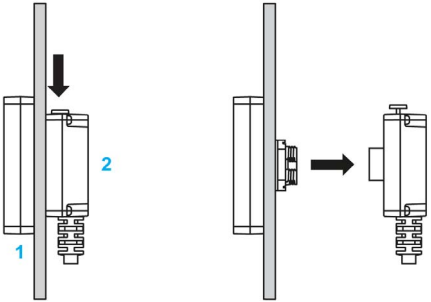
Step	Action
1	<p>Push down the yellow lock button of the rear module and remove it from the display module/rear module separation cable.</p>  <p>1 Rear module 2 Display module/rear module separation cable</p>
2	<p>Push down the lock button of the display module/rear module separation cable and remove it from the display module.</p>  <p>1 Display module 2 Display module/rear module separation cable</p>

---

## Section 5.2

### Electrical Requirements

---

#### What Is in This Section?

This section contains the following topics:

Topic	Page
Power Supply Characteristics and Wiring	76
Connecting the Power Cord	78
Connecting the Power Supply	80

## Power Supply Characteristics and Wiring

### Overview

This section provides the wiring diagrams and the characteristics of the DC power supply.

### Power Supply Voltage Range

If the specified voltage range is not maintained, outputs may not switch as expected. Use appropriate safety interlocks and voltage monitoring circuits.

<b>⚠ DANGER</b>
<b>FIRE HAZARD</b>
Use only the recommended wire sizes for I/O channels and power supplies.
<b>Failure to follow these instructions will result in death or serious injury.</b>

<b>⚠ WARNING</b>
<b>UNINTENDED EQUIPMENT OPERATION</b>
Do not exceed any of the rated values specified.
<b>Failure to follow these instructions can result in death, serious injury, or equipment damage.</b>

### DC Power Supply Characteristics

Reference		Specification	
<b>Voltage</b>	rated	24 Vdc	
	range	20.4...28.8 Vdc	
<b>Power interruption time</b>		10 ms at 20.4 Vdc	
<b>Inrush current</b>		30 A at 25 °C and at 28.8 Vdc	
<b>Continuous output power</b>	with display	LT-4000M (Modular Type DIO) and PFXXM4200TP (3.5 inch display module) : 9 W	LT-4000M (Modular Type Analog) and PFXXM4300TP (5.7 inch display module): 13 W
	without display	LT-4000M (Modular Type DIO): 7 W	LT-4000M (Modular Type Analog): 10 W
<b>Insulation Resistance</b>		500 Vdc, 10 MΩ or more	
<b>Isolation between DC power supply and internal logic, I/O, and protective ground (PE)</b>		500 Vdc for 1 minute	
<b>Power supply reverse protection</b>		Yes	

## DC Power Supply Wiring Diagram

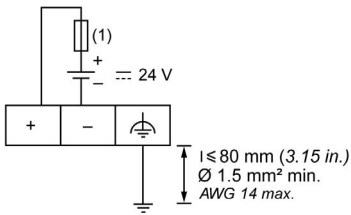

- 1 Use an external, slow-blow, 2 A type T fuse.

### **⚠ DANGER**

#### **FIRE HAZARD**

Use only the recommended wire sizes for I/O channels and power supplies.

**Failure to follow these instructions will result in death or serious injury.**

### **⚠ WARNING**

#### **UNINTENDED EQUIPMENT OPERATION**

Do not exceed any of the rated values specified.

**Failure to follow these instructions can result in death, serious injury, or equipment damage.**

## Power Interruption

The Voltage Drop is variable depending upon the load to the power supply of the controller, but generally a minimum of 10 ms is maintained as specified by IEC standards.

LT enters power-down status when a momentary power interruption of the rated voltage continues for 10 ms or longer. When the LT enters power-down status, it stops all calculations, even if there are instructions that are not completed.

For example, when the LT enters power-down status while 100 words of data are being transferred by a FMOV instruction, the transfer stops midway. Consequently, design your program with consideration to power-down occurrences.

### **⚠ WARNING**

#### **UNINTENDED EQUIPMENT OPERATION**

- Individually monitor each source of power used in the LT system including input power supplies, output power supplies, and the power supply to the controller to allow appropriate system shutdown during power system interruptions.
- The inputs monitoring each of the power supply sources must be unfiltered inputs.

**Failure to follow these instructions can result in death, serious injury, or equipment damage.**

## Connecting the Power Cord

### Introduction

Follow these instructions when supplying power to the unit:

- When the frame ground (FG) terminal is connected, verify the wire is grounded. Not grounding the unit can result in excessive Electromagnetic Interference (EMI). Grounding is required to meet EMC level immunity.
- The shield ground (SG) and FG terminals are connected internally in the unit.
- Remove power before wiring to the power terminals of the unit.
- The unit uses 24 Vdc power. Using any other level of power can damage both the power supply and the unit.
- Since the unit is not equipped with a power switch, connect a power switch to the unit's power supply.
- Use copper wire rated for 75 °C (167°F) or higher.

### Power Cord Preparation

Before using your power cord:

- Verify that the ground wire is the same gauge or heavier than the power wires.
- Do not use aluminum wires for the power cord for power supply.
- If the conductor end (individual) wires are not twisted correctly, the end wires may either short loop to each other or against an electrode. To avoid this, use D25CE/AZ5CE cable ends.
- Use wires that are 0.75 to 2.5 mm<sup>2</sup> (18 to 12 AWG) for the power cord, and twist the wire ends before attaching the terminals.
- The conductor type is solid or stranded wire.
- To reduce electromagnetic noise, make the power cord as short as possible.

### Power Plug

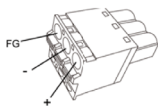

Connection	Wire
+	24 Vdc
-	0 Vdc
FG	Grounded terminal connected to the unit chassis

### Connecting the Power Cord

The table explains how to connect the power plug:

Step	Action
1	Confirm the power cord is not connected to the power supply.
2	Check the rated voltage and remove the "DC24V" sticker on the DC power supply connector.
3	Remove 10 mm (0.39 in.) of the vinyl membrane off the ends of the power code wires.
4	If using stranded wire, twist the ends. Tinning the ends with solder reduces risk of fraying and ensures good electrical transfer.

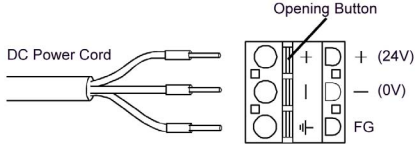
Step	Action
5	Push the Opening button with a small and flat screwdriver to open the desired pin hole.
6	Insert each pin terminal into its corresponding hole. Release the Opening button to clamp the pin in place. 
7	After inserting all three pins, insert the power plug into the power connector on the LT.

**NOTE:**

- Do not solder the wire directly to the power receptacle pin.
- The power supply cord must meet the specification shown above. Twist the power cords together, up to the power plug, for EMC compliance.

## Connecting the Power Supply

### Precautions

- Use the power plug to connect the power cord to the power connector on the side of the rear module.
- Use DC input with a Class 2 power supply.
- Do not bundle the power supply cord with, or keep close to, main circuit lines (high voltage, high current), or I/O signal lines.
- Connect a lightning surge absorber to handle power surges.

Excessive stress on the power connection or attempting to install a rear module with the power cables connected may disconnect, or cause damage, to the power connections. This can cause short circuits, fire, or unintended equipment operation.

⚠ WARNING

**SHORT CIRCUITS, FIRE, OR UNINTENDED EQUIPMENT OPERATION**

Avoid excessive force on the power cable to prevent accidental disconnections:

- Securely attach power cables to the panel or cabinet.
- Secure the power plug of the rear module.
- Install and fasten the rear module on the installation panel or cabinet prior to connecting power supply and communication lines.

**Failure to follow these instructions can result in death, serious injury, or equipment damage.**

### Power Supply Connections

For maintenance purpose, use the following connection diagram to set up your power supply connections. However, when terminals A2 and B2 (signal name: Q1, Q0) are wired to external I/O, use the same power source for external I/O and the LT.

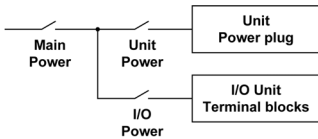

When wiring terminals A2 and B2 (signal name: Q1, Q0) to external I/O.

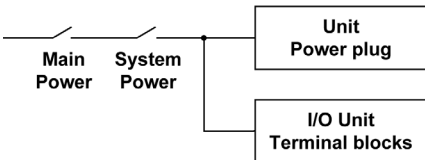

#### NOTE:

- When connector A2 and B2 (Signal Name: Q1, Q0) are wired to external I/O, turn on the LT before turning on the external device. Otherwise the wrong signal for Pulse Output, PWM Output and High-speed Counter (Synchronize Output) will be output. When transferring a program that turns off or resets the LT, first turn off the external device. When using a system with multiple power supplies, please note there is also a power supply in the external device.



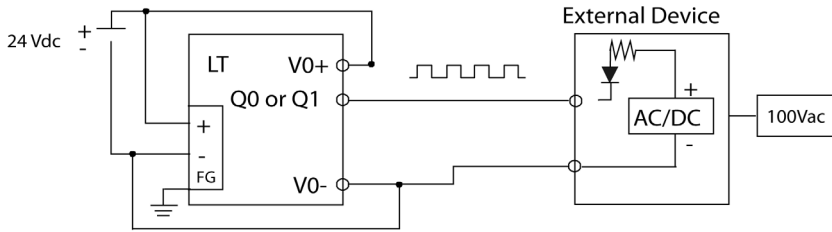

- Ground the surge absorber separately from the rear module.
- Select a surge absorber that has a maximum circuit voltage greater than the peak voltage of the power supply.

The diagram illustrates a lightning surge absorber connection:

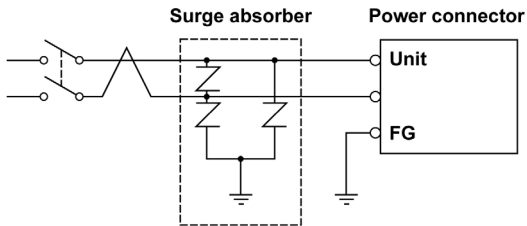

# Section 5.3

## USB Port

---

### Overview

This section presents the USB port.

### What Is in This Section?

This section contains the following topics:

Topic	Page
USB Data Transfer Cable - USB Driver Installation	83
USB (Type A)	84
USB (mini-B)	86

## USB Data Transfer Cable - USB Driver Installation

### Important Information

Follow these instructions to avoid damage to the cable connector or the unit:

- Do not connect the USB data transfer cable until told to do so in the instructions.
- Insert the connector at the correct angle when connecting the USB data transfer cable to the PC or to the unit.
- Hold the connector, not the cable itself when disconnecting the cable.
- Use the port designated during installation. If the cable is unplugged from the port designated during installation and connected to a different port, the Operating System (OS) does not recognize the new port.
- Restart the PC and quit all resident applications before reinstalling the software if the installation does not complete successfully.

**NOTE:** For transfer methods, refer to the following manual: GP-Pro EX Reference Manual "Transferring project files via USB transfer cable".

### USB Host Interface Characteristics

	USB (Type A) Interface	USB (mini-B) Interface
Connector	USB 2.0 (Type A) x 1	USB 2.0 (mini-B) x 1
Power Supply Voltage	5 Vdc $\pm$ 5%	–
Maximum Current Supplied	500 mA	–
Maximum Transmission Distance	5 m (16.4 ft)	

## USB (Type A)

### Introduction

# ⚠ WARNING

## RISK OF EXPLOSION IN HAZARDOUS LOCATIONS

In hazardous locations as described in ANSI/ISA - 12.12.01:

- Confirm that the USB cable has been attached with the USB cable clamp before using the USB host interface.
- Remove power before attaching or detaching any connector(s) to or from the unit.

**Failure to follow these instructions can result in death, serious injury, or equipment damage.**

When using a USB device, you can attach a USB holder to the USB interface on the side of the unit to help prevent the USB cable from being disconnected.

### Attaching the USB Holder

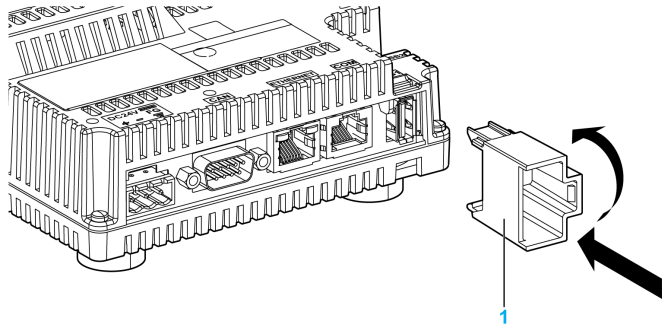
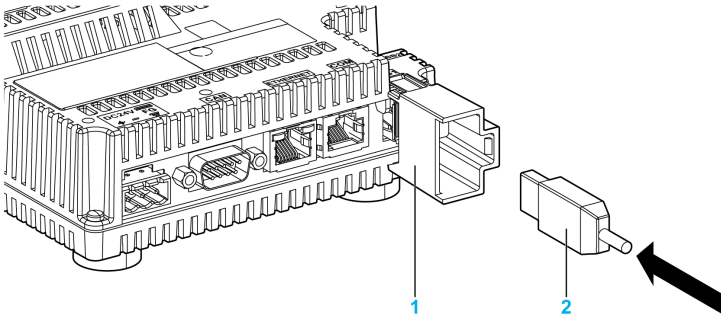
Step	Action
1	<p>Attach the USB holder to the USB host interface on the rear module. Hook the upper pick of the USB holder to the attachment hole of the main unit, and insert the lower pick as shown below to affix the USB holder.</p>  <p>1 USB holder</p>
2	<p>Insert the USB cable into the USB host interface.</p>  <p>1 USB holder 2 USB cable</p>

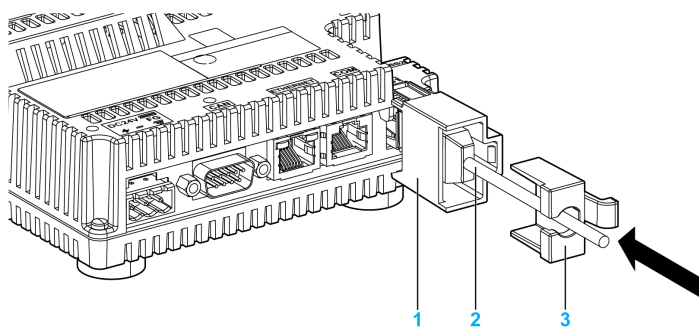
Step	Action
3	<p>Attach the USB cover to fix the USB cable in place. Insert the USB cover into the tab of the USB holder.</p>  <p>1 USB holder 2 USB cable 3 USB cover</p>

**Removing the USB Holder**

Push the tab of the USB holder to the left and then remove the USB cover.

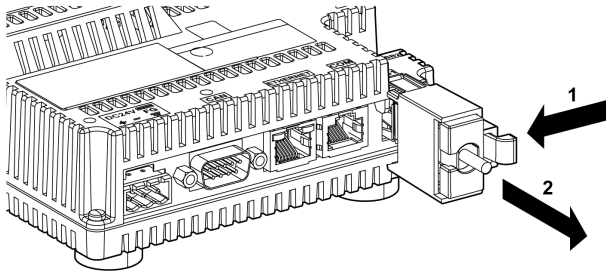

## USB (mini-B)

### Introduction

### **⚠ WARNING**

#### **RISK OF EXPLOSION IN HAZARDOUS LOCATIONS**

In hazardous locations as described in ANSI/ISA - 12.12.01:

- Confirm that the USB cable has been attached with the USB cable clamp before using the USB host interface.
- Remove power before attaching or detaching any connector(s) to or from the unit.

**Failure to follow these instructions can result in death, serious injury, or equipment damage.**

When using a USB device, you can attach a USB holder to the USB interface on the unit to help prevent the USB cable from being disconnected.

**NOTE:** The USB holder is supplied in the accessory kit PFXZGMAK1 (sold separately).

### Attaching the USB Holder

Step	Action
1	Insert the USB cable into the USB host interface.

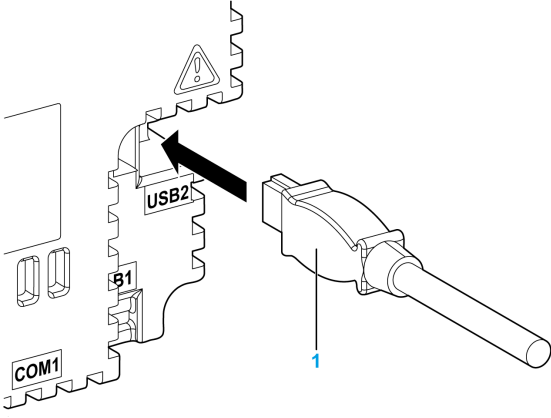

1 USB cable

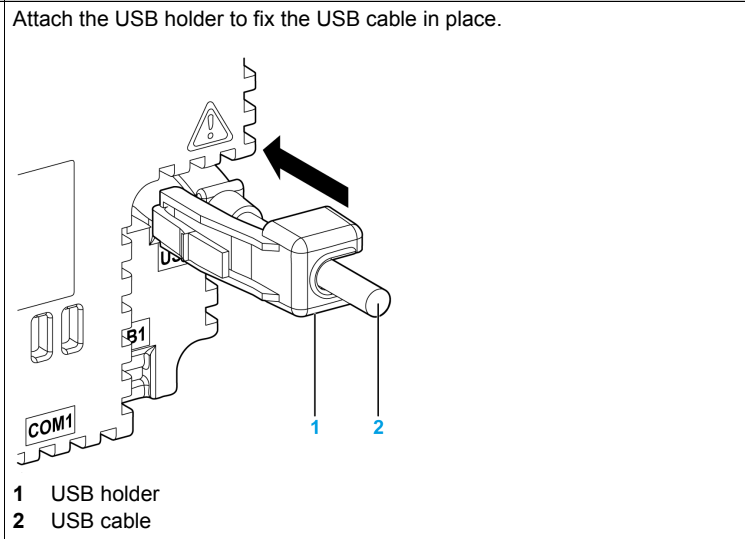
Step	Action
2	<p>Attach the USB holder to fix the USB cable in place.</p>  <p>1 USB holder 2 USB cable</p>

**Removing the USB Holder**

Push down the tab of the USB holder and then remove the USB holder.

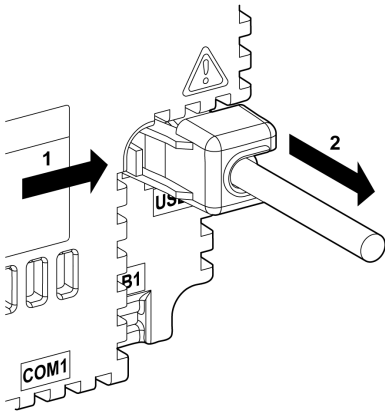





---

# Part II

## LT Unit and Display Modules

---

### Overview

This part describes the LT Unit and the display modules.

### What Is in This Part?

This part contains the following chapters:

Chapter	Chapter Name	Page
6	LT-4201TM/4301TM (Modular Type DIO)	91
7	LT-4201TM/4301TM (Modular Type Analog)	99
8	Display Modules	111



---

# Chapter 6

## LT-4201TM/4301TM (Modular Type DIO)

---

### Overview

This chapter describes the LT-4201TM/4301TM (Modular Type DIO).

### What Is in This Chapter?

This chapter contains the following topics:

Topic	Page
Presentation	92
Digital Inputs	94
Digital Outputs	96

## Presentation

### Terminal Blocks

The figure shows the terminal blocks:

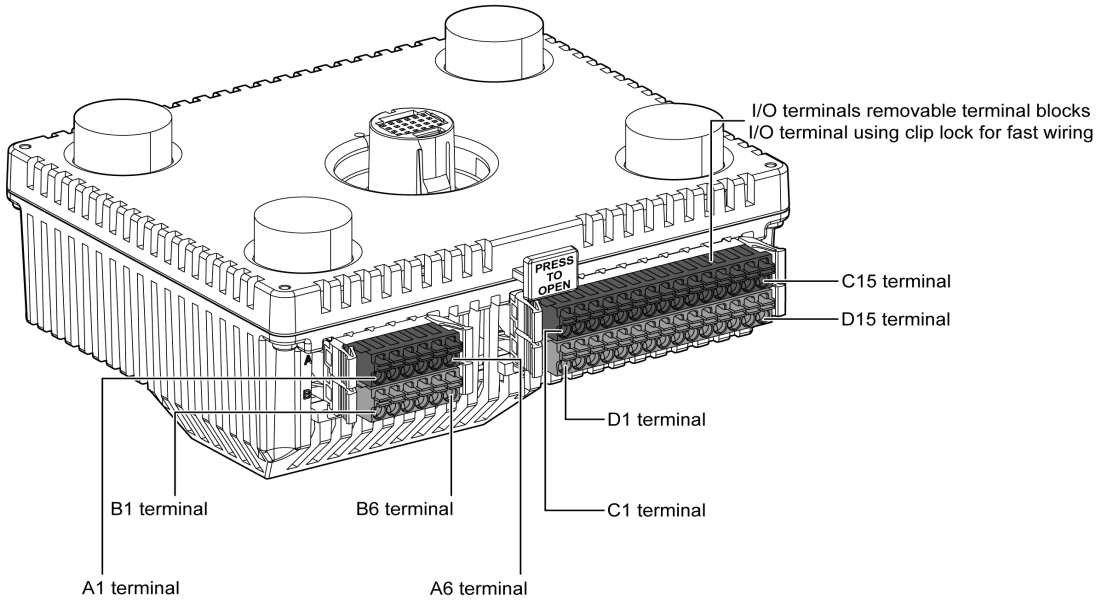

The figure shows the pin assignment of the terminal blocks:

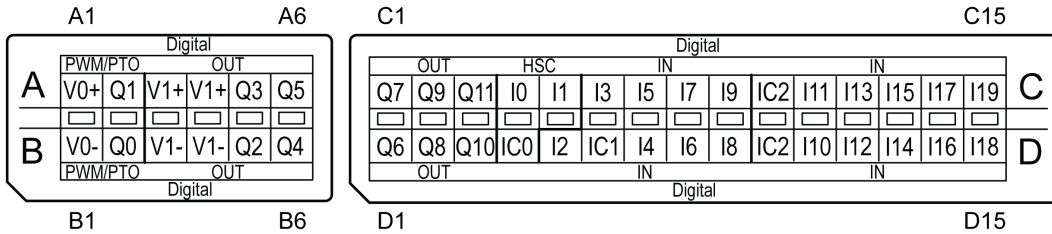

**NOTE:** Confirm the connector label ABCD and the stamp ABCD on the unit before wiring.

The table shows the group and signal names of the terminal blocks:

Pin Arrangement	Group	Pin	Signal Name	Group	Pin	Signal Name
	Fast Output	A1	V0+	Fast Output	B1	V0-
		A2	Q1		B2	Q0
	Standard Output	A3	V1+	Standard Output	B3	V1-
		A4	V1+		B4	V1-
		A5	Q3		B5	Q2
		A6	Q5		B6	Q4

The table shows the group and signal names of the terminal blocks:

Pin Arrangement	Group	Pin	Signal Name	Group	Pin	Signal Name
	Standard Output	C1	Q7	Standard Output	D1	Q6
		C2	Q9		D2	Q8
		C3	Q11		D3	Q10
	Fast Input/Standard Input	C4	I0	Fast Input/Standard Input	D4	IC0
		C5	I1		Standard Input	D5
	Standard Input	C6	I3	D6		IC1
		C7	I5	D7		I4
		C8	I7	D8		I6
		C9	I9	D9		I8
		C10	IC2	D10		IC2
		C11	I11	D11		I10
		C12	I13	D12		I12
		C13	I15	D13		I14
		C14	I17	D14		I16
		C15	I19	D15	I18	

**⚡ ⚠ DANGER**

**HAZARD OF ELECTRIC SHOCK, EXPLOSION OR ARC FLASH**

- Disconnect all power from all equipment including connected devices prior to removing any covers or doors, or installing or removing any accessories, hardware, cables, or wires except under the specific conditions specified in the appropriate hardware guide for this equipment.
- Always use a properly rated voltage sensing device to confirm the power is off where and when indicated.
- Replace and secure all covers, accessories, hardware, cables, and wires and confirm that a proper ground connection exists before applying power to the unit.
- Use only the specified voltage when operating this equipment and any associated products.

**Failure to follow these instructions will result in death or serious injury.**

## Digital Inputs

### Overview

The rear module is equipped with 20 digital inputs.

**⚠ DANGER**

**FIRE HAZARD**  
 Use only the recommended wire sizes for I/O channels and power supplies.  
**Failure to follow these instructions will result in death or serious injury.**

### Input Management Functions Availability

The table describes the possible usage of the rear module inputs:

Function		Input Function		
		Standard Input	Fast Input	Counter Input
Filtering Time		0.5 ms...30 ms	None/4 μs/40 μs	
<b>Fast Input</b> <sup>1</sup>	I0	X	X	X
	I1	X	X	X
<b>Digital Input</b>	I2	X	–	–
	I3	X	–	–
	I4	X	–	–
	I5	X	–	–
	I6	X	–	–
	I7	X	–	–
	I8	X	–	–
	I9	X	–	–
	I10	X	–	–
	I11	X	–	–
	I12	X	–	–
	I13	X	–	–
	I14	X	–	–
	I15	X	–	–
	I16	X	–	–
	I17	X	–	–
	I18	X	–	–
I19	X	–	–	

X Yes  
 – No  
<sup>1</sup> Can also be used as a regular input

**NOTE:** You can use filters and functions to manage the LT's inputs.

### Wiring Diagram

The figure describes the wiring diagram of the LTs digital inputs. Refer to Terminal Blocks.

Fast Input/Standard Input:

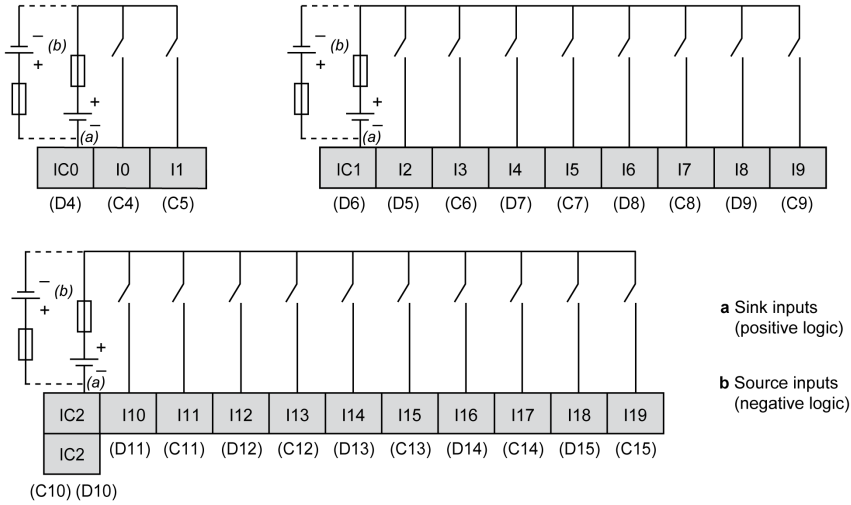

**⚠ WARNING**

**UNINTENDED EQUIPMENT OPERATION**

Do not connect wires to unused terminals or terminals marked "Not Connected (N.C.)".

**Failure to follow these instructions can result in death, serious injury, or equipment damage.**

**⚠ WARNING**

**UNINTENDED EQUIPMENT OPERATION**

Use a single power source for the sensor and actuator.

**Failure to follow these instructions can result in death, serious injury, or equipment damage.**

## Digital Outputs

### Overview

The rear module is equipped with 12 digital outputs that you can manage.

** DANGER**

**FIRE HAZARD**

Use only the recommended wire sizes for I/O channels and power supplies.

**Failure to follow these instructions will result in death or serious injury.**

### Output Management Functions Availability

The table describes the possible usage of the rear module outputs:

Function		Output Function	
		Standard Output	Pulse Output/PWM Output
<b>Fast Output<sup>1</sup></b>	Q0	–	X
	Q1	–	X
<b>Digital Output</b>	Q2	X	–
	Q3	X	–
	Q4	X	–
	Q5	X	–
	Q6	X	–
	Q7	X	–
	Q8	X	–
	Q9	X	–
	Q10	X	–
	Q11	X	–
X Yes – No <sup>1</sup> Cannot be used as a regular output			

### Fast Output Wiring Diagram

For additional information about fast output protection, refer to Protecting Outputs from Inductive Load Damage (see page 31).

** WARNING**

**UNINTENDED EQUIPMENT OPERATION**

Be sure to wire the outputs correctly according to the wiring diagram.

**Failure to follow these instructions can result in death, serious injury, or equipment damage.**



### Wiring Diagram

The figure describes the wiring diagram of the LTs digital outputs. Refer to Terminal Blocks.

**NOTE:** When terminals A2 and B2 (signal name: Q1, Q0) are wired to external I/O, use the same power source for external I/O and the LT. Refer to Power Supply Connections.

Standard output:

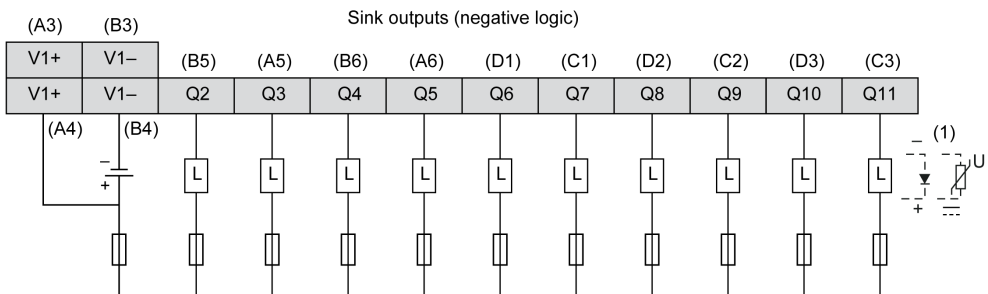
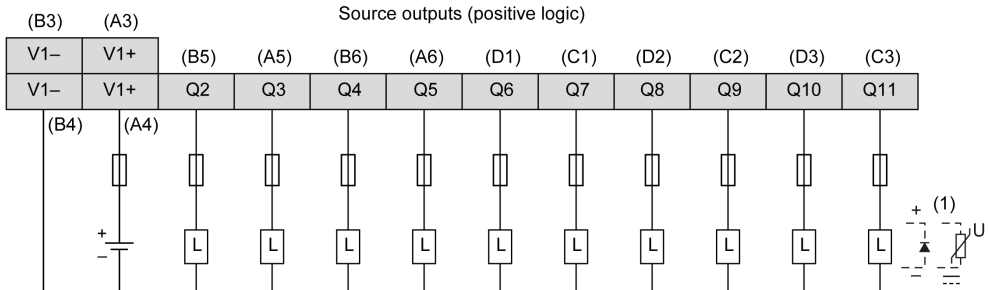

(1) When connecting as power surges

Pulse Output/PWM Output/High-speed Counter (Synchronize Output):

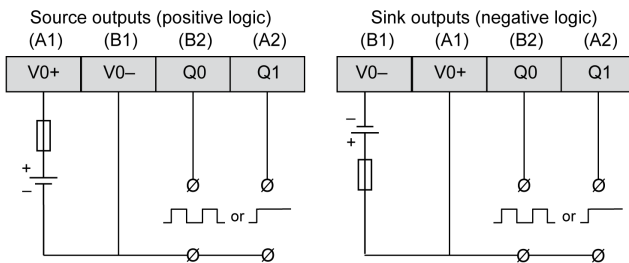

**NOTE:**

Q0 and Q1 circuits are push-pull circuits. The following is the operation of the push-pull circuit at the sink output and the source output:

- Sink output: +24(V) is output to terminal Q0, Q1 when the logic for Q0, Q1 is off.
- Source output: 0(V) is output to terminal Q0, Q1 when the logic for Q0, Q1 is off.

Standard Output terminals Q2 or later are common open collector outputs. Do not connect Fast Output terminals Q0, Q1, and Standard Output terminals Q2 or later. It will short. If you add a manual circuit to terminal Q0, Q1, isolate the manual circuit and terminal Q0, Q1 with a relay. Without isolation, it will short.

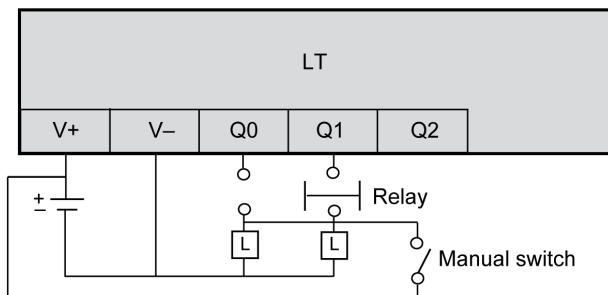

## **⚠ WARNING**

### **UNINTENDED EQUIPMENT OPERATION**

Do not connect wires to unused terminals or terminals marked "Not Connected (N.C.)".

**Failure to follow these instructions can result in death, serious injury, or equipment damage.**

---

# Chapter 7

## LT-4201TM/4301TM (Modular Type Analog)

---

### Overview

This chapter describes the LT-4201TM/4301TM (Modular Type Analog).

### What Is in This Chapter?

This chapter contains the following topics:

Topic	Page
Presentation	100
Digital Inputs	102
Digital Outputs	104
Analog Inputs and Analog Outputs	107

## Presentation

### Terminal Blocks

The figure shows the terminal blocks:

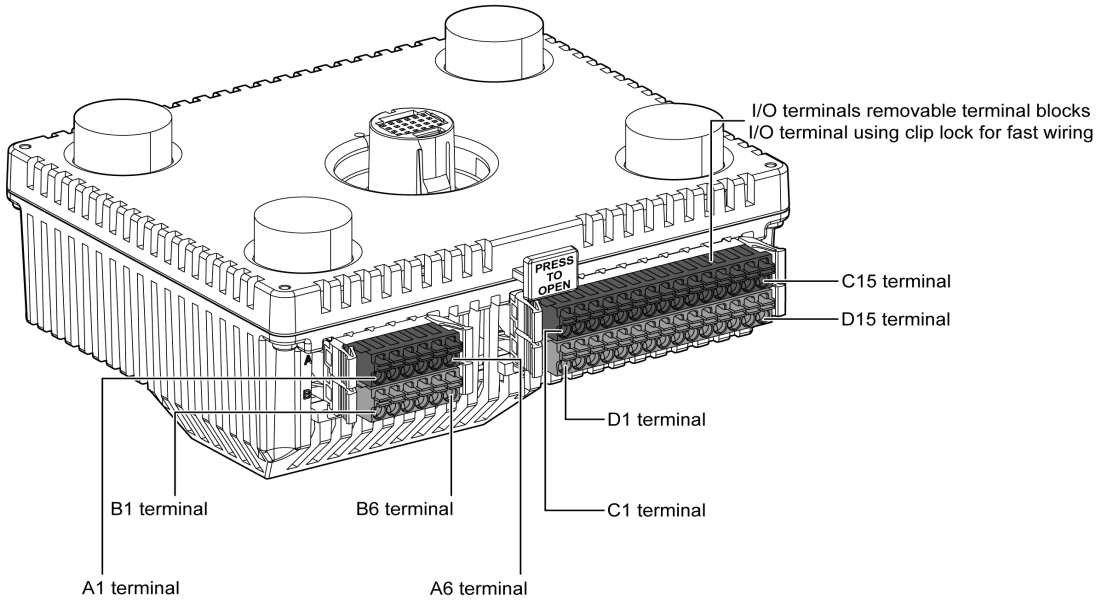

The figure shows the pin assignment of the terminal blocks:

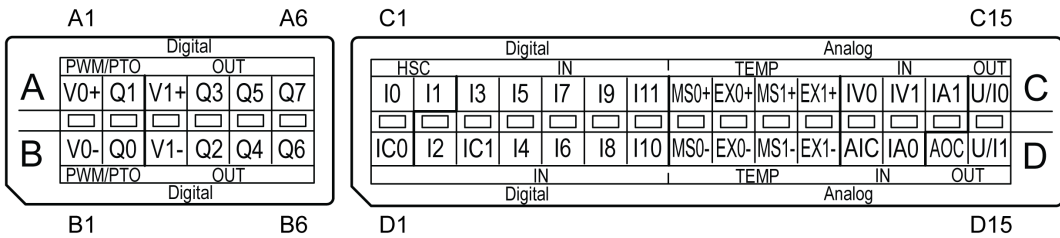

**NOTE:** Confirm the connector label ABCD and the stamp ABCD on the unit before wiring.

The table shows the group and signal names of the terminal blocks:

Pin Arrangement	Group	Pin	Signal Name	Group	Pin	Signal Name
	Fast Output	A1	V0+	Fast Output	B1	V0-
		A2	Q1		B2	Q0
	Standard Output	A3	V1+	Standard Output	B3	V1-
		A4	Q3		B4	Q2
		A5	Q5		B5	Q4
		A6	Q7		B6	Q6

The figure shows the group and the signal name of the terminal blocks:

Pin Arrangement	Group	Pin	Signal Name	Group	Pin	Signal Name
	Fast Input/Standard Input	C1	I0	Fast Input/Standard Input	D1	IC0
		C2	I1		Standard Input	D2
	Standard Input	C3	I3	D3		IC1
		C4	I5	D4		I4
		C5	I7	D5		I6
		C6	I9	D6		I8
	C7	I11	D7	I10		
	Temperature Input	C8	MS0+	Temperature Input	D8	MS0-
		C9	EX0+		D9	EX0-
		C10	MS1+		D10	MS1-
		C11	EX1+		D11	EX1-
	Analog Input	C12	IV0	Analog Input	D12	AIC
		C13	IV1		D13	IA0
		C14	IA1	Analog Output	D14	AOC
	Analog Output	C15	U/I0		D15	U/I1

**⚡ ⚠ DANGER**

**HAZARD OF ELECTRIC SHOCK, EXPLOSION OR ARC FLASH**

- Disconnect all power from all equipment including connected devices prior to removing any covers or doors, or installing or removing any accessories, hardware, cables, or wires except under the specific conditions specified in the appropriate hardware guide for this equipment.
- Always use a properly rated voltage sensing device to confirm the power is off where and when indicated.
- Replace and secure all covers, accessories, hardware, cables, and wires and confirm that a proper ground connection exists before applying power to the unit.
- Use only the specified voltage when operating this equipment and any associated products.

**Failure to follow these instructions will result in death or serious injury.**

## Digital Inputs

### Overview

The rear module is equipped with 12 digital inputs.

**⚠ DANGER**

**FIRE HAZARD**

Use only the recommended wire sizes for I/O channels and power supplies.

**Failure to follow these instructions will result in death or serious injury.**

### Input Management Functions Availability

The table describes the possible usage of the rear module inputs:

Function		Input Function		
		Standard Input	Fast Input	Counter Input
Filtering Time		0.5...30.0 ms	None/4 μs/40 μs	
<b>Fast Input</b> <sup>1</sup>	I0	X	X	X
	I1	X	X	X
<b>Digital Input</b>	I2	X	–	–
	I3	X	–	–
	I4	X	–	–
	I5	X	–	–
	I6	X	–	–
	I7	X	–	–
	I8	X	–	–
	I9	X	–	–
	I10	X	–	–
	I11	X	–	–

**X** Yes  
**–** No  
<sup>1</sup> Can also be used as a regular input

**NOTE:** You can use filters and functions to manage the LT' inputs.

### Wiring Diagram

The figure describes the wiring diagram of the LTs digital inputs. Refer to Terminal Blocks.

High-speed Input/Standard Input:

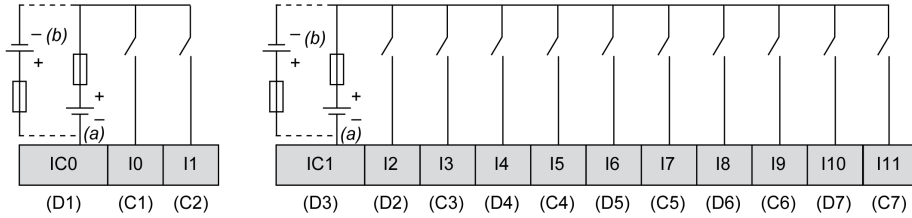

- a Sink inputs (positive logic)
- b Source inputs (negative logic)

**⚠ WARNING**

**UNINTENDED EQUIPMENT OPERATION**

Do not connect wires to unused terminals or terminals marked "Not Connected (N.C.)".

**Failure to follow these instructions can result in death, serious injury, or equipment damage.**

**⚠ WARNING**

**UNINTENDED EQUIPMENT OPERATION**

Use a single power source for the sensor and actuator.

**Failure to follow these instructions can result in death, serious injury, or equipment damage.**

## Digital Outputs

### Overview

The rear module is equipped with 8 digital outputs that you can manage.

**⚠ DANGER**

**FIRE HAZARD**

Use only the recommended wire sizes for I/O channels and power supplies.

**Failure to follow these instructions will result in death or serious injury.**

### Output Management Functions Availability

The table describes the possible usage of the rear module outputs:

Function		Output Function	
		Standard Output	Pulse Output/PWM Output
<b>Fast Output</b> <sup>1</sup>	Q0	–	X
	Q1	–	X
<b>Digital Output</b>	Q2	X	–
	Q3	X	–
	Q4	X	–
	Q5	X	–
	Q6	X	–
	Q7	X	–
<b>X</b> Yes <b>–</b> No <sup>1</sup> Cannot be used as a regular output			

### Fast Output Wiring Diagram

For additional information about fast output protection, refer to Protecting Outputs from Inductive Load Damage (see page 31).

**⚠ WARNING**

**UNINTENDED EQUIPMENT OPERATION**

Be sure to wire the outputs correctly according to the wiring diagram.

**Failure to follow these instructions can result in death, serious injury, or equipment damage.**

### Wiring Diagram

The figure describes the wiring diagram of the LTs digital outputs. Refer to Terminal Blocks.

**NOTE:** When terminals A2 and B2 (signal name: Q1, Q0) are wired to external I/O, use the same power source for external I/O and the LT. Refer to Power Supply Connections.



Standard output:

Source outputs (positive logic)

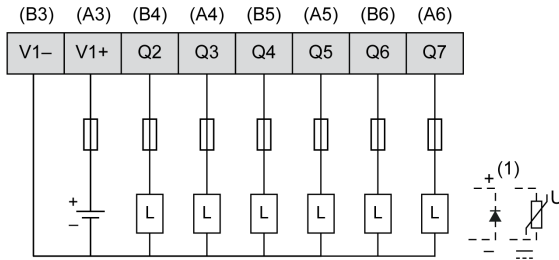

Sink outputs (negative logic)

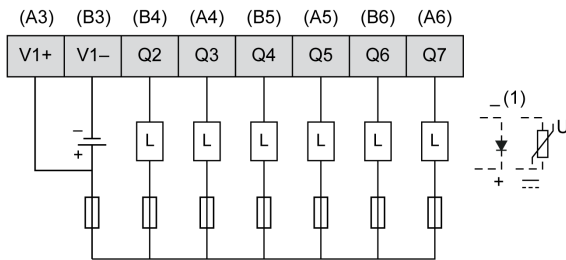

(1) When connecting as power surges

Pulse Output/PWM Output/High-speed Counter (Synchronize Output):

Source outputs (positive logic)

Sink outputs (negative logic)

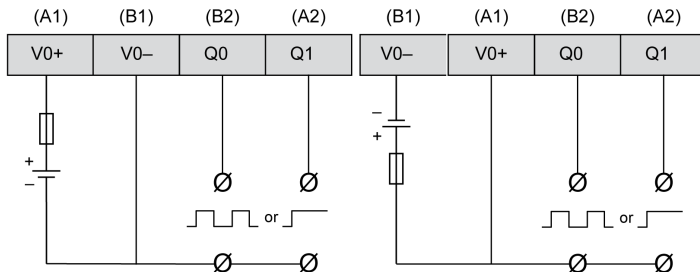

**NOTE:**

Q0 and Q1 circuits are push-pull circuits. The following is the operation of the push-pull circuit at the Sink Output and the Source Output:

- Sink Output: +24(V) is output to terminal Q0, Q1 when the logic for Q0, Q1 is off.
- Source Output: 0(V) is output to terminal Q0, Q1 when the logic for Q0, Q1 is off.

Standard Output terminals Q2 or later are common open collector outputs. Do not connect Fast Output terminals Q0, Q1 and Standard Output terminals Q2 or later. It will short. If you add a manual circuit to terminal Q0, Q1, isolate the manual circuit and terminal Q0, Q1 with a relay. Without isolation, it will short.

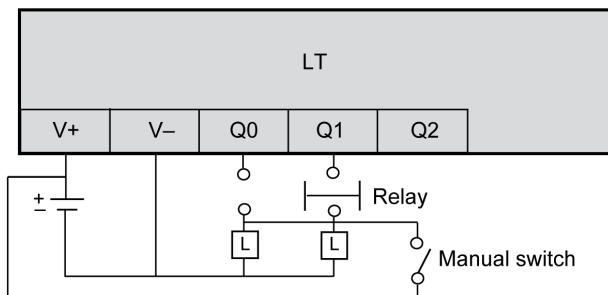

**⚠ WARNING**

**UNINTENDED EQUIPMENT OPERATION**

Do not connect wires to unused terminals or terminals marked "Not Connected (N.C.)".

**Failure to follow these instructions can result in death, serious injury, or equipment damage.**

## Analog Inputs and Analog Outputs

### Overview

The rear module is equipped with:

- 2 ch Thermocouple/Temperature Probes (16-bit)
- 2 ch analog inputs (13-bit)
- 2 ch analog outputs (12-bit)

### DANGER

#### FIRE HAZARD

Use only the recommended wire sizes for I/O channels and power supplies.

**Failure to follow these instructions will result in death or serious injury.**

### WARNING

#### UNINTENDED EQUIPMENT OPERATION

Do not exceed any of the rated values specified.

**Failure to follow these instructions can result in death, serious injury, or equipment damage.**

### Analog Features

There are different terminal connection points for each type of analog signal.

Since current and voltage requires different adjustment values, you also need to configure the desired type of input or output signal:

- -10...10 Vdc voltage signal (default).
- 0...10 Vdc voltage signal
- 0...20 mA current signal.
- 4...20 mA current signal.

The temperature measurement values are converted into numeric values that can be processed by the controller. For temperature measurements, the temperature rear module returns the measured value in 0.1°C (0.18°F) steps.

The table shows the analog features:

Number and Type of Channels	Digital Resolution	Voltage/Current
2 ch inputs	13 bit	-10...10 Vdc (digital value -4096 to 4095) 0...10 Vdc (digital value 0 to 8192) 0...20 mA (digital value 0 to 8192) 4...20 mA (digital value 0 to 8192)
2 ch inputs	16 bit	RTD (Resistance Temperature Detector): PT100/PT1000/NI100/NI1000 Thermocouple: J, K, R, B, S, T, E, N
2 ch outputs	12 bit	-10...10 Vdc (digital value -2048 to 2047) 0...10 Vdc (digital value 0 to 4095) 0...20 mA (digital value 0 to 4095) 4...20 mA (digital value 0 to 4095)

**Wiring Diagram**

The figure describes the wiring diagram of the rear module analog inputs and analog outputs:

**Analog inputs**

**Voltage input**

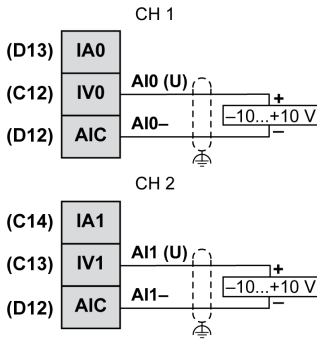

**Current input**

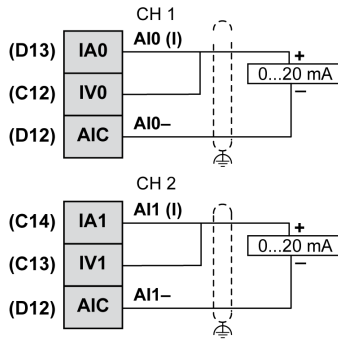

**Analog outputs**

**Voltage and current outputs**

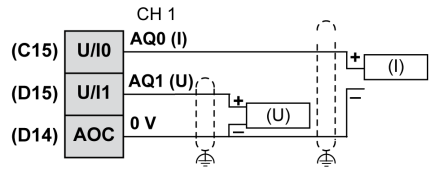

**Analog inputs PT100**

**3-wiring**

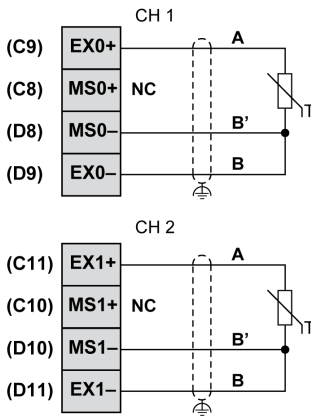

**2-wiring**

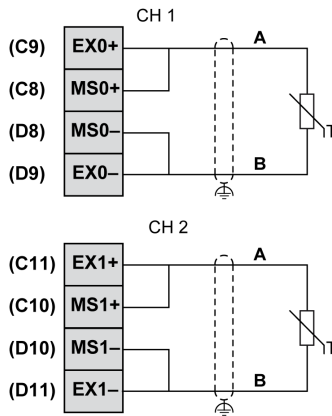

**Thermocouple**

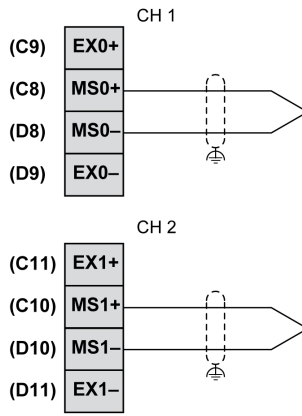

**⚠ WARNING**

**UNINTENDED EQUIPMENT OPERATION**

Do not connect wires to unused terminals or terminals marked "Not Connected (N.C.)".

**Failure to follow these instructions can result in death, serious injury, or equipment damage.**

**⚠ WARNING**

**IMPROPER GROUNDING CAN CAUSE UNINTENDED EQUIPMENT OPERATION**

- Use cables with insulated shielded jackets for analog I/O, fast I/O and communication signals.
- Ground shielded cables for analog I/O, fast I/O and communication signals at a single point <sup>1</sup>.
- Always comply with local wiring requirements regarding grounding of cable shields.

**Failure to follow these instructions can result in death, serious injury, or equipment damage.**

<sup>1</sup>Multipoint grounding is permissible if connections are made to an equipotential ground plane dimensioned to help avoid shielded cable damage in the event of power system short circuit currents.

## **WARNING**

### **UNINTENDED EQUIPMENT OPERATION**

- Use shielded cables wherever specified for inputs, outputs, and communication connections.
- Properly ground the cable shields as indicated in the related documentation.
- Route communication and I/O cables separately from power cables.

**Failure to follow these instructions can result in death, serious injury, or equipment damage.**

## **NOTICE**

### **INOPERABLE EQUIPMENT**

Be sure that the physical wiring of the analog circuit is compatible with the software configuration for the analog channel.

**Failure to follow these instructions can result in equipment damage.**



# Chapter 8

## Display Modules

### Panel Overview

#### Introduction

The LT is a Human Machine Interface product that has an operating voltage of 24 Vdc.

The table describes the LT characteristics:

Part Number	Screen Size	Screen (Pixel) Resolution	Color Definition	Screen Type
LT-4201TM (Modular Type DIO)	3.5 in.	320 x 240 (QVGA)	65536 colors and LED backlight	TFT
LT-4201TM (Modular Type Analog)				
3.5 inch display module				
LT-4301TM (Modular Type DIO)	5.7 in.			
LT-4301TM (Modular Type Analog)				
5.7 inch display module				

#### Critical Systems, Detected Alarms and Handling Requirements

Critical detected alarm indicators and system functions require independent and redundant protection hardware and/or mechanical interlocks.

If the unit for any reason becomes inoperative (for example, an inoperative backlight) it may be difficult or impossible to identify operation. Operations that may present a hazard if not immediately executed, such as emergency stop, must be provided independently of the unit. The design of the control system must take into account an inoperative unit (backlight) and the operator may be unable to control the machine or respond to detected errors with the unit.

After turning OFF the LT, be sure to wait at least 10 seconds before turning it ON again. The LT may not operate correctly if it is restarted too quickly.

---

## WARNING

### LOSS OF CONTROL

- Consider the potential failure modes of control paths in the machine control system design, such as:
  - The possibility of backlight failure,
  - Unanticipated link transmission delays or failures,
  - The operator being unable to control the machine,
  - The operator making errors in the control of the machine.
- Design outside the LT operations such as emergency stop, safety circuits, interlocks that operate with opposing actions such as clockwise/counterclockwise rotation, and circuits that prevent machine damage with positioning limits on top, bottom, and movement.
- For important operations handled by switches, design your system to use a separate hardware device. This is to reduce the occurrence of incorrect outputs or malfunctions.
- Observe all accident prevention regulations and local safety guidelines.<sup>1</sup>
- Test individually and thoroughly each implementation of the equipment for correct operation before service.

**Failure to follow these instructions can result in death, serious injury, or equipment damage.**

<sup>1</sup> For additional information, refer to NEMA ICS 1.1 (latest edition), "Safety Guidelines for the Application, Installation, and Maintenance of Solid State Control" and to NEMA ICS 7.1 (latest edition), "Safety Standards for Construction and Guide for Selection, Installation and Operation of Adjustable-Speed Drive Systems" or their equivalent governing your particular location.

## WARNING

### UNINTENDED EQUIPMENT OPERATION

- Do not use the LT as a control unit for system critical operations such as start/stop or output control of motors.
- Do not use the LT as the only warning device for critical alarms such as device overheat or device over-current.

**Failure to follow these instructions can result in death, serious injury, or equipment damage.**

### Handling the LCD

The following characteristics are specific to the LCD and are considered normal behavior:

- LCD screen may show unevenness in the brightness of certain images or may appear different when seen from outside the specified viewing angle. Extended shadows, or cross-talk, may also appear on the sides of screen images.
- LCD screen pixels may contain black and white-colored spots and color display may seem to have changed over time.
- When the same image is displayed on the screen for a long period, an after-image may appear when the image is changed. If this happens, turn off the unit, wait 10 seconds, and then restart it.

**NOTE:** Do not display the same image for a long time. Change the screen image periodically.



**⚠ CAUTION****SERIOUS EYE AND SKIN INJURY**

The liquid present in the LCD contains an irritant:

- Avoid direct skin contact with the liquid.
- Wear gloves when you handle a broken or leaking unit.
- Do not use sharp objects or tools in the vicinity of the LCD touch panel.
- Handle the Panel carefully to prevent puncture, bursting, or cracking of the Panel material.

**Failure to follow these instructions can result in injury or equipment damage.**

If the Panel is damaged and any liquid comes in contact with your skin, immediately rinse the area with running water for at least 15 min.

If the liquid gets in your eyes, immediately rinse your eyes with running water for at least 15 minutes and consult a doctor.

**Using Touch Panel Correctly****⚠ WARNING****UNINTENDED EQUIPMENT OPERATION**

- Operate the touch panel with only one finger.
- Do not activate two or more points of the touch panel simultaneously.

**Failure to follow these instructions can result in death, serious injury, or equipment damage.**

Use only one finger to select an object on the touch panel.

If the touch panel receives pressure at two or more points at the same time, an unintended object could be selected.



---

# Part III

## LT Controller Panels

---

### Overview

This part describes how to use LT controller panels.

### What Is in This Part?

This part contains the following chapters:

Chapter	Chapter Name	Page
9	Communication Interface	117
10	Specifications	125
11	Maintenance	141



---

# Chapter 9

## Communication Interface

---

### What Is in This Chapter?

This chapter contains the following topics:

Topic	Page
Ethernet Port	118
CANopen Master Unit	120
Serial Interface (COM1)	123

## Ethernet Port

### Introduction

The LT is equipped with an IEEE802.3 compliant Ethernet communication port that transmits and receives data at 10 Mbps or 100 Mbps.

### Ethernet Port Connector

The figure shows the location of the RJ45 Ethernet port on the rear module:

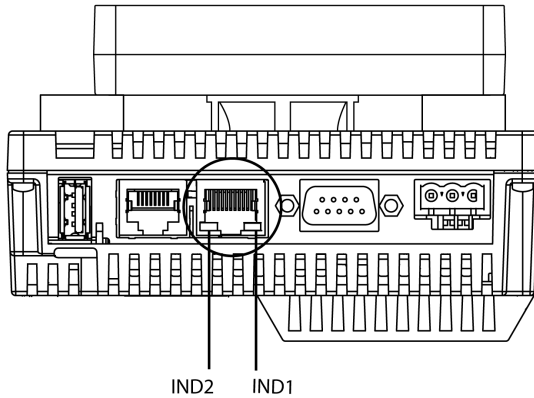

Do not confuse the RJ45 Ethernet connector with the RJ45 serial interface.

**NOTE:** When you use a 1:1 connection to connect to a device such as PC, you can use a cross cable, but we recommend using a hub.

### Characteristics

The table describes the different Ethernet characteristics:

Characteristic	Description
Connector type	RJ45
Driver	<ul style="list-style-type: none"> <li>• 10 M half duplex (auto negotiation)</li> <li>• 100 M full duplex (auto negotiation)</li> </ul>
Cable type	Shielded
Automatic cross-over detection	Yes

### Pin Assignment

The figure shows the RJ45 Ethernet connector pin assignment:

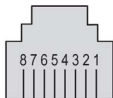

The table describes the RJ45 Ethernet connector pins:

Pin	Signal
1	TD+
2	TD-
3	RD+

Pin	Signal
4	–
5	–
6	RD-
7	–
8	–

**NOTE:** The LT supports the MDI/MDIX auto-crossover cable function. You do not have to use special Ethernet crossover cables to connect devices directly to this port (connections without an Ethernet hub or switch).

### Status LEDs

The table describes the Ethernet status LEDs operations:

Label	Description	LED		
		Color	Status	Description
IND1	Ethernet status	Green	Off	No connection or subsequent transmission failure.
			On	Data transmission is available.
IND2	Ethernet activity	Green	Off	No data transmission.
			On	Data transmission is occurring.

## CANopen Master Unit

### CANopen Capabilities

The table describes the LT CANopen master features:

Maximum number of slaves on the bus	63 CANopen slave devices
Maximum length of CANopen fieldbus cables	According to the CAN specification (see Cable Length and Transmission Speed).

### Characteristics

The table describes the CAN characteristics:

Characteristic	Description
Standard	CAN-CiA (ISO 11898-2:2002 Part 2) <sup>1</sup>
Connector type	Sub-D9, 9 pins male
Protocol supported	CANopen
CAN power distribution	No
Maximal cable length	See table below <sup>4</sup>
Isolation	See note <sup>2</sup>
Bit rate	See table below <sup>4</sup>
Line termination	No. See note <sup>3</sup>

<sup>1</sup> Part 1 and Part 2 of ISO 11898:2002 are equivalent to ISO 11898:1993.

<sup>2</sup> The isolation of the rear module is 500 Vac RMS between the module and the terminal blocks connected to the rear module. The two parts reference the same functional ground (FE) through specific components designed to reduce effects of electromagnetic interference. These components are rated at 30 Vdc or 60 Vdc. This effectively reduces isolation of the entire system from the 500 Vac RMS.

<sup>3</sup> resistor (R) is needed on each end of the CAN field bus.

<sup>4</sup> The table describes the maximum cable lengths:

Baud rate		800 Kbit/s	250 Kbit/s	125 Kbit/s	50 Kbit/s	20 Kbit/s	10 Kbit/s
Maximum cable length	m	25	250	500	1000	2500	5000
	ft.	82.02	820.20	1640.41	3280.83	8202.07	16404.15

### Pin Assignment

The graphic describes the pins of the CANopen interface:

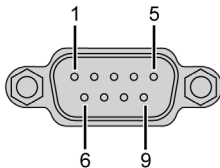



The table describes the pins of the CANopen interface:

PIN	Signal	Description
1	N.C.	Reserved
2	CAN_L	CAN_L bus Line (Low)
3	CAN_GND	CAN 0 Vdc
4	N.C.	Reserved
5	CAN_SHLD	N.C.
6	GND	0 Vdc
7	CAN_H	CAN_H bus Line (High)
8	N.C.	Reserved
9	N.C.	Reserved

The shield is connected to pin 6, the 0 Vdc pin.

**NOTE:** Pin 9 is not connected internally. The controller does not provide power on CAN\_V+.

## WARNING

### UNINTENDED EQUIPMENT OPERATION

Do not connect wires to unused terminals or terminals marked “Not Connected (N.C.)”.

**Failure to follow these instructions can result in death, serious injury, or equipment damage.**

## Status LED

The table describes the CAN status LED:

Marking	Description	LED	
		Color	Description
CAN STS	CANopen status	Green / Red	See CAN STS status LED below

The table describes the CAN STS status LED:

CAN0 LED	CANopen Status	Description
OFF	No CANopen configured	CANopen is not active in the application.
Single flash red / with green ON	Acceptable detected error limit threshold has been reached	The controller has detected that the maximum number of error frames has been reached or exceeded.
Double flash red / with green ON	Node Guarding or Heartbeat event	The controller has detected either a Node Guarding or Heartbeat exception for the CANopen master or slave device.
Red ON	Bus off	The CANopen bus is stopped.
Green ON	The CANopen bus is operational.	

**NOTE:** CANopen LED is mounted alongside the cover.

## CANopen Data Transfer Settings

The CANopen networking concept is based on the international standard CAN. CANopen is defined as a uniform application layer by the DS301 specifications of the CiA (CAN in Automation).

### **CANopen Cable Arrangement**

The CANopen interface uses a D-SUB 9-pin plug connector. The plug is assigned with the CAN\_H, CAN\_L and, CAN\_GND connections. CAN\_H and CAN\_L are the two conductors of the CAN bus. CAN\_GND is the common reference potential.

**NOTE:**

- The resistance of the cable value must be 70 mΩ/m (1.77 mΩ/in.) or less.
- To minimize signal reflections from the end of the cable, a 120 Ω. (5%, 1/4 W maximum) line termination must be placed at both ends of the bus.

### **CANopen Communication Cable and Connectors**

**NOTE:** CANopen communication cables and cable connectors are not supplied with the CANopen Master Unit. The user must prepare the cables. Please use your own cables or cable connectors with your guarantee.

### **Recommended Cable Connector**

D-SUB (DIN41652) connector compliant with CANopen Standard (CiA DR-303-1)

### **CANopen Recommended Transfer Cable**

Transfer cable (a twisted-pair cable with a shield) compliant with CANopen Standard (CiA DR-303-1)

## Serial Interface (COM1)

### Introduction

The serial interface is used to communicate with devices supporting the Modbus protocol as a master.

To enable communications through serial links, the LT includes an RS-232/485 serial link.

### Serial Port Connector

The figure shows the location of the RJ45 serial port on the rear module:

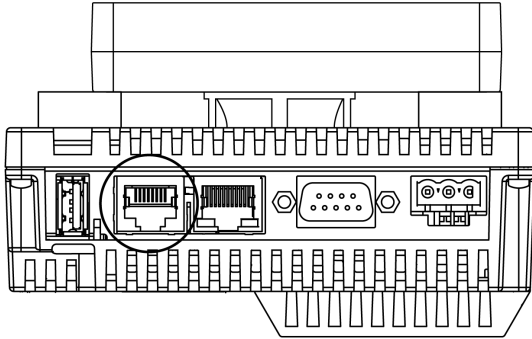

Do not confuse the RJ45 serial port with the RJ45 Ethernet interface.

### RS-232C Characteristics

Characteristic		Description
Connector type		RJ45
Isolation		None
Maximum baud rate		115,200 bps
Cable	Type	Shielded
	Maximum length	15 m (49 ft)
5 Vdc power supply for RS-485		No

**NOTE:** The maximum baud rate for the serial link port depends on the protocol used.

### RS-485 Characteristics

Characteristic		Description
Connector type		RJ45
Isolation		None
Maximum baud rate		115,200 bps
Cable	Type	Shielded
	Maximum length	200 m (656 ft)
Polarization		Setting is required via software when connecting Multiple LTs. Refer to the "GP-Pro EX Device/PLC Manual" for the setting.
5 Vdc power supply for RS-485		No

**Pin Assignment**

The table describes the pin assignment of the RJ45 connector:

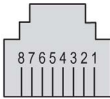
Pin	RS-232C	RS-485	Description	RJ45 connector
1	RxD	N.C.	Received data (RS-232C)	
2	TxD	N.C.	Transmitted data (RS-232C)	
3	N.C.	N.C.	Not connected	
4	N.C.	D1+	Differential data (RS-485)	
5	N.C.	D0-	Differential data (RS-485)	
6	RTS	RTS	Ready to send	
7	N.C.	N.C.	Not connected	
8	GND	GND	Signal ground	

⚠ WARNING
UNINTENDED EQUIPMENT OPERATION
Do not connect wires to unused terminals or terminals marked "Not Connected (N.C.)".
<b>Failure to follow these instructions can result in death, serious injury, or equipment damage.</b>

---

# Chapter 10

## Specifications

---

### Overview

This chapter presents the LT specifications.

### What Is in This Chapter?

This chapter contains the following sections:

Section	Topic	Page
10.1	General Specifications	126
10.2	Functional Specifications	128

---

# Section 10.1

## General Specifications

---

### General Specifications

#### Electrical Specifications

The table shows the electrical specifications of LT:

Part Number	Rated Input Voltage	Input Voltage Limits	Acceptable Voltage Drop	Power Consumption	In-Rush Current	Voltage Endurance between power terminal and frame ground (FG)	Insulation Resistance between power terminal and FG
LT-4201TM (Modular Type DIO)	24 Vdc	20...28.8 Vdc	10 ms or less at 20.4 Vdc	9 W or less	30 A or less at 28.8 Vdc	500 Vdc for 1 minute	10 MΩ or higher at 500 Vdc
LT-4201TM (Modular Type Analog)	24 Vdc	20...28.8 Vdc	10 ms or less at 20.4 Vdc	12 W or less			
LT-4301TM (Modular Type DIO)	24 Vdc	20...28.8 Vdc	10 ms or less at 20.4 Vdc	10 W or less			
LT-4301TM (Modular Type Analog)	24 Vdc	20...28.8 Vdc	10 ms or less at 20.4 Vdc	13 W or less			

#### Environmental Specifications

The table shows the environmental specifications of LT:

	Characteristic	Specification	
Mechanical Environment	Vibration immunity (operating)	IEC 61131-2	
	Protection structure	NEMA TYPE 4X (indoors, with panel embedded)	
	Protection (front module)	IP65f - (IEC 60529)	
	Protection (rear module)	IP 20 - (IEC 60529)	
	Shock immunity (operating)	IEC 61131-2 15 gn 11 ms	
	Cooling method	Natural air circulation	
	Weight	LT-4201TM (Modular Type DIO): 496 g (17.49 oz) LT-4301TM (Modular Type DIO): 749 g (26.41 oz)	LT-4201TM (Modular Type Analog): 531 g (18.73 oz) LT-4301TM (Modular Type Analog): 784 g (27.65 oz)
	Color	Front module: PT404 Rear module: RAL 7032	
	Material	<ul style="list-style-type: none"> <li>● front module: PC/PBT</li> <li>● rear module: PC/PBT</li> <li>● front module: PAA+GF</li> <li>● rear module: PC/PBT</li> </ul>	<ul style="list-style-type: none"> <li>● front module: PC/PBT</li> <li>● rear module: PC/PBT</li> <li>● front module: PAA+GF</li> <li>● rear module: PC/PBT</li> </ul>

---

# Section 10.2

## Functional Specifications

---

### Overview

This section presents the LT functional specifications of the display, memory, and I/O.

### What Is in This Section?

This section contains the following topics:

Topic	Page
Display	129
Digital Inputs	130
Digital Outputs	132
Analog Inputs and Analog Outputs	134
Internal Circuits	138
Memory and Touch Panel	140



## Display

### Display Specifications

The table shows the display specifications of the LT:

Items	LT-4201TM 3.5 inch Display Module	LT-4301TM 5.7 inch Display Module
Type	TFT Color LCD	TFT Color LCD
Resolution (pixels)	320 x 240 (QVGA)	320 x 240 (QVGA)
Active display area (W x H)	70.56 x 52.92 mm (2.78 x 2.08 in.)	115.2 x 86.4 mm (4.53 x 3.40 in.)
Display Colors	65536 colors	65536 colors
Backlight	White LED	White LED
	Non-exchangeable	Non-exchangeable
	LED ON / OFF control, adjustable screen saver activation time	LED ON / OFF control, adjustable screen saver activation time
Brightness adjustment	16 levels of adjustment available via touch panel in the configuration menu	
Language Fonts <sup>(1)</sup>	Japanese, ASCII, Chinese (Simplified), Chinese (Traditional), Korean, Cyrillic, Thai	
Character sizes	8 x 8, 8 x 16, 16 x 16 and 32 x 32 pixel fonts	8 x 8, 8 x 16, 16 x 16 and 32 x 32 pixel fonts
Font sizes	Width can be expanded 1...8 times. Height can be expanded 1/2 and 1...8 times.	Width can be expanded 1...8 times. Height can be expanded 1/2 and 1...8 times.
8 x 8 pixels	40 characters per row x 30 rows	40 characters per row x 30 rows
8 x 16 pixels	40 characters per row x 15 rows	40 characters per row x 15 rows
16 x 16 pixels	20 characters per row x 15 rows	20 characters per row x 15 rows
32 x 32 pixels	10 characters per row x 7 rows	10 characters per row x 7 rows
(1) Please refer to the GP-Pro EX Reference Manual for details on font types and character codes.		

## Digital Inputs

### Digital Input Characteristics

#### **WARNING**

##### **UNINTENDED EQUIPMENT OPERATION**

Do not exceed any of the rated values specified.

**Failure to follow these instructions can result in death, serious injury, or equipment damage.**

The table describes the characteristics of the digital inputs:

Characteristic		Value
Rated current		5 mA
Inrush values	Voltage	30 Vdc
	Current	6.29 mA max.
Input impedance		4.9 k $\Omega$
Input type		Sink/Source
Rated voltage		24 Vdc
Maximum Allowable Voltage		28.8 Vdc
Input limit values	ON Voltage	15 Vdc or more (15...28.8 Vdc)
	OFF Voltage	5 Vdc or less (0...5 Vdc)
	ON Current	2.5 mA or more
	OFF Current	1.0 mA or less
Isolation	Method	Photo coupler Isolation
	Between internal logic	500 Vdc
Filtering		0.5 ms x N (N is 0 to 63)
IEC61131-2 edition 3 type		Type 1
Compatibility		Supports 2 wire and 3 wire sensors
Cable type and length		Shielded: Maximum 100 m (328 ft) Non-shielded: 50 m (164 ft)
Terminal blocks		Type: 3.5 mm (0.137 in.) pitch Terminal blocks are removable
Input paralleling		No

### High-speed Counter Digital Input Characteristics

#### **WARNING**

##### **UNINTENDED EQUIPMENT OPERATION**

Do not exceed any of the rated values specified.

**Failure to follow these instructions can result in death, serious injury, or equipment damage.**

The table describes the characteristics of the High-speed Counter and Pulse Catch inputs:

Characteristic		Value
Rated current	Voltage	24 Vdc
	Current	7.83 mA
Inrush values	Voltage	30 Vdc
	Current	9.99 mA
Input impedance		3.2 kΩ
Input type		Sink/Source
Rated voltage		24 Vdc
Maximum Allowable Voltage		28.8 Vdc
Input limit values	ON Voltage	15 Vdc or more
	OFF Voltage	5 Vdc or less
	ON Current	5 mA or more
	OFF Current	1.5 mA or less
Isolation	Method	Photo coupler Isolation
	Between internal logic	500 Vdc
Filtering		None, 4 μs, 40 μs
IEC61131-2 edition 3 type		Type 1
Compatibility		Supports 2 wire and 3 wire sensors
Cable	Type	Shielded
	Length	Maximum 10 m (33 ft)
Terminal blocks		Type: 3.5 mm (0.137 in.) pitch Terminal blocks are removable
Maximum frequency		<ul style="list-style-type: none"> <li>● 100 kHz is the maximum frequency for single-phase</li> <li>● 50 kHz is the maximum frequency for 2 phase</li> <li>● Duty Rate: 45...55%</li> </ul>
Phase Counting Mode		<ul style="list-style-type: none"> <li>● Single-phase</li> <li>● 2 Phase x2</li> <li>● 2 Phase x4</li> <li>● 2 Phase x2 Reverse</li> <li>● 2 Phase x4 Reverse</li> </ul>
Response time	Marker	1 ms
	Preload	1 ms
	Prestrobe	1 ms
	Synchronize output	2 ms
Min. Pulse Width (Pulse Input)		<div style="display: flex; justify-content: space-around;"> <div style="text-align: center;"> <p>Counter</p> </div> <div style="text-align: center;"> <p>Pulse Catch Input signal ON width</p> </div> </div>
Input paralleling		No

## Digital Outputs

### Transistor Output Characteristics

<b> WARNING</b>
<b>UNINTENDED EQUIPMENT OPERATION</b>
Do not exceed any of the rated values specified.
<b>Failure to follow these instructions can result in death, serious injury, or equipment damage.</b>

The table describes the characteristics of the transistor outputs:

Characteristic		Value
Rated voltage		24 Vdc
Output range		19.2...28.8 Vdc
Output type		Sink/Source
Rated current		0.3 A/point, 3.0 A/common
Residual voltage		1.5 Vdc or less for I = 0.1 A
Delay		Off to on (0.3 A load): 0.1 ms On to off (0.3 A load): 1 ms <b>NOTE:</b> The delay is not including the cable delay.
Isolation	Method	Photo coupler Isolation
	Between internal logic	500 Vdc
Minimum resistor load		80 Ω at 24 Vdc
Cable length		Non-shielded: 50 m (164 ft)
Protection against short circuit		No
Terminal blocks		Type: 3.5 mm (0.137 in.) pitch Terminal blocks are removable
<b>NOTE:</b> Refer to Protecting Outputs from Inductive Load Damage for additional information on this topic.		

### Pulse Output/PWM Output/High-speed Counter (Synchronize Output) Characteristics

<b> WARNING</b>
<b>UNINTENDED EQUIPMENT OPERATION</b>
Do not exceed any of the rated values specified.
<b>Failure to follow these instructions can result in death, serious injury, or equipment damage.</b>

The table describes the characteristics of the Pulse Output/PWM Output/High-speed Counter (Synchronize Output):

Characteristic	Value
Output type	Sink/Source
Rated voltage	24 Vdc
Power supply input range	19.2...28.8 Vdc

Characteristic		Value	
Power supply reverse protection		Yes	
Pulse output/PWM output current		50 mA/point, 100 mA/common	
Response time for original input		2 ms	
Isolation resistance	Between fast outputs and internal logic	10 MΩ or more	
	Between power supply port and protective earth ground (PE) = 500 Vdc	10 MΩ or more	
Residual voltage	for I = 0, 1 A	1.5 Vdc or less	
Delay		Off to on (50 mA load): 2.5 μs On to off (50 mA load): 2.5 μs <b>NOTE:</b> The delay is not including the cable delay.	
Minimum load impedance		80 Ω	
Maximum Pulse output frequency		50 KHz	
Maximum PWM output frequency		65 kHz	
Accuracy Pulse Output/PWM Output	Frequency	Accuracy	Duty
	10...100 Hz	0.1%	0...100%
	101...1000 Hz	1%	1...99%
	1.001...20 kHz	5%	5...95%
	20.001...45 kHz	10%	10...90%
45.001...65 kHz	15%	15...85%	
Duty rate range		1...99%	
Cable	Type	Shielded, including 24 Vdc power supply	
	Length	Maximum 5 m (16 ft)	
Terminal blocks		Type: 3.5 mm (0.137 in.) pitch Terminal blocks are removable	
<b>NOTE:</b> When using the acceleration/deceleration pulse output, there is a 1% maximum error for the frequency.			

## Analog Inputs and Analog Outputs

### Analog Input Characteristics

The table describes the characteristics of the analog inputs:

Characteristic		Voltage input	Current input
Number of maximum input channels		2	
Input type		Single-ended	
Input range		-10... 10 Vdc/0...10 Vdc	0...20 mA/4...20 mA
Input impedance		1 M $\Omega$ or more	250 $\pm$ 0.11% $\Omega$
Sample duration time		10 ms per channel + 1 scan time	
Total input system transfer time		20 ms + 1 scan time	
Input tolerance	Maximum deviation at 25°C (77°F) without electromagnetic disturbance	$\pm$ 1% of the full scale	
	Maximum deviation	$\pm$ 2.5% of the full scale	
Digital resolution		13 bits	
Temperature drift		$\pm$ 0.06% of the full scale	
Common mode characteristics		80 db	
Cross talk		60 db	
Non-linearity		$\pm$ 0.4% of full scale	
Input value of LSB		5 mV	10 $\mu$ A
Maximum allowed overload (no damages)		$\pm$ 30 Vdc (less than 5 minutes) $\pm$ 15 Vdc (No damage)	$\pm$ 30 mA dc
Protection type		Photo coupler between input and internal circuit	
Cable	Type	Shielded	
	Length	Must be less than 3 m for IEC61131-2 conformance. Maximum transmission distance is 10 m.	
Terminal blocks		Type: 3.5 mm (0.137 in.) pitch Terminal blocks are removable	
Isolation		External input: Photo coupler isolation Between channels: Non-isolated	

### Temperature Input (Temperature Probes) Characteristics

#### **WARNING**

##### **UNINTENDED EQUIPMENT OPERATION**

Do not exceed any of the rated values specified.

**Failure to follow these instructions can result in death, serious injury, or equipment damage.**

The table describes the characteristics of the Temperature Input (Temperature Probes):

Input Characteristics		
Input sensor type		Pt100/Pt1000/Ni100/Ni1000
Input temperature range		Pt100/Pt1000: -200...600°C (-328...1112°F) Ni100/Ni1000: -20...200°C (-4...392°F)
Measuring current	Pt100/Ni100	1.12 mA ± 3.5%
	Pt1000/Ni1000	0.242 µA ± 3.5%
Input impedance		Typically 10 MΩ
Sample duration time		10 ms+1 cycle time
Wiring type		2-wire or 3-wire connection configured by software for all inputs
Conversion mode		Sigma delta type
Input filter		Low pass
Resolution temperature value		0.1°C (0.18°F)
Detection type		Open circuit (detection on each channel)
Input tolerance*	Maximum deviation at 25°C (77°F) without electromagnetic disturbance	± 5°C (41°F)
	Maximum deviation at 25...50°C (77...122°F)	Pt type: ± 5.6°C (42.08°F) Ni type: ± 5.2°C (41.36°F)
Temperature drift		30 ppm/°C
Digital resolution		16 bits
Rejection in differential mode	50/60 Hz	Typically 60 dB
Common mode rejection		Typically 80 dB
Isolation method		Photo coupler Isolation
Permitted input signal		±5 Vdc max.
Cable length	Pt100/Ni100	20 Ω or less
	Pt1000/Ni1000	200 Ω or less
Terminal blocks		Type: 3.5 mm (0.137 in.) pitch Terminal blocks are removable
Noise resistance - cable		Shielded cable is necessary
* Excluding errors caused by the wiring		

**Temperature Input (Thermocouple) Characteristics**

 <b>WARNING</b>
<b>UNINTENDED EQUIPMENT OPERATION</b>
Do not exceed any of the rated values specified.
<b>Failure to follow these instructions can result in death, serious injury, or equipment damage.</b>

The table describes the characteristics of the Temperature Input (Thermocouple):

Input Characteristics		
Input sensor type		Thermocouple
Input type range <sup>(1)</sup>		J (-200...760°C) (-328...1400°F) K (-240...1370°C) (-400...2498°F) R (0...1600°C) (32...2912°F) B (200...1800°C) (392...3272°F) S (0°C...1600°C) (32...2912°F) T (-200...400°C) (-328...752°F) E (-200...900°C) (-328...1652°F) N (-200...1300°C) (-328...2372°F)
Input impedance		Typically 10 MΩ
Sample duration time		10 ms+1 cycle time
Conversion mode		Sigma delta type
Digital resolution		16 bits
Input filter		Low pass
Resolution temperature value		0.1°C (0.18°F) (Type J)
Detection type		
Input tolerance		Open circuit (detection on each channel)
	Maximum deviation at 25°C (77°F) without electromagnetic disturbance	0.2 % of the full scale, plus standard point of compensation precision at +/- 6 °C.
	Maximum deviation	0.28% of full scale range
Temperature drift		30 ppm/°C
Input tolerance - terminal temperature compensation		± 5°C (41°F) after 10 min.
Cold junction compensation in the temperature range (0...50°C (122°F))		Internal cold junction error: +/- 6°C (42.8°F) after operating 45 minutes.
Rejection in differential mode	50/60 Hz	Typically 60 dB
Common mode rejection		Typically 80 dB
Isolation method		Photo coupler isolation
Permitted input signal		± 5 Vdc max.
Warm up time		45 minutes
Terminal blocks		Type: 3.5 mm (0.137 in.) pitch Terminal blocks are removable
Noise resistance - cable		Shielded cable is necessary
(1) Temperature measurement on PCB at terminal block for cold junction compensation.		



## Analog Output Characteristics

### WARNING

#### UNINTENDED EQUIPMENT OPERATION

Do not exceed any of the rated values specified.

**Failure to follow these instructions can result in death, serious injury, or equipment damage.**

The table describes the characteristics of the analog outputs:

Characteristic		Voltage Output	Current Output
Maximum number of outputs		2	
Output range		-10... 10 Vdc/0...10 Vdc	0...20 mA / 4...20 mA
Load impedance		2 k $\Omega$ or more	300 $\Omega$ or less
Application load type		Resistive load	
Settling time		10 ms	
Total output system transfer time		10 ms + 1 scan time	
Output tolerance	Maximum deviation at 25°C (77°F) without electromagnetic disturbance	$\pm$ 1% of the full scale	
	Maximum deviation	$\pm$ 2.5% of the full scale	
Digital resolution		12 bits	
Temperature drift		$\pm$ 0.06% of the full scale	
Output ripple		$\pm$ 50 mV	
Cross talk		60 db	
Non-linearity		$\pm$ 0.5% of the full scale	
Output value of LSB		6 mV	12 $\mu$ A
Protection type		Photo coupler between input and internal circuit	
Output protection		Short circuit protection: Yes Open circuit protection: Yes	
Output behavior if input power supply is less than the power failed threshold		Set to 0	
Cable	Type	Shielded	
	Length	Must be less than 3 m for IEC61131-2 conformance. Maximum transmission distance is 10 m.	
Terminal blocks		Type: 3.5 mm (0.137 in.) pitch Terminal blocks are removable	
Isolation		External input: Photo coupler isolation Between channels: Non-isolated	

# Internal Circuits

## LT-4201TM/4301TM (Modular Type DIO) Internal Circuit

### Terminal Blocks

The circuit configuration of I0, I1 is shown as follows:

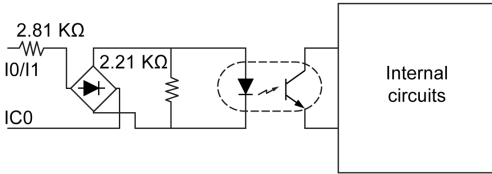

The circuit configuration from I2 to I19 is shown as follows:

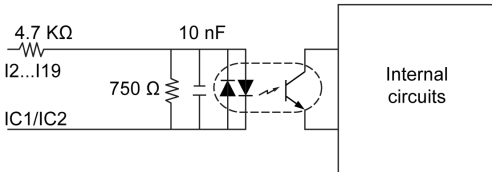

The circuit configuration of Q0 and Q1 is shown as follows:  
It is source type

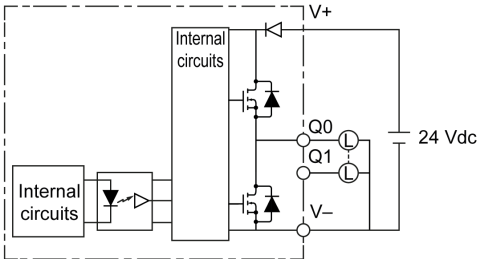

The circuit configuration from Q2 to Q11 is shown as follows:  
It is source type

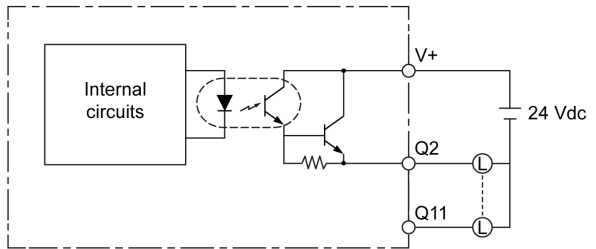

The circuit configuration of Q0 and Q1 is shown as follows:  
It is sink type

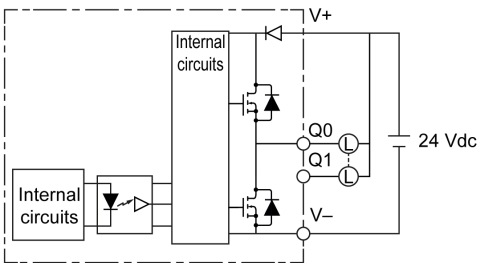

The circuit configuration from Q2 to Q11 is shown as follows:  
It is sink type

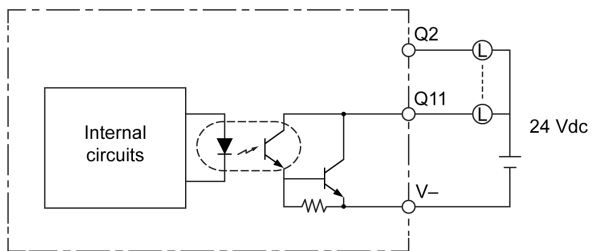

## LT-4201TM/4301TM (Modular Type Analog) Internal Circuit

### Terminal Blocks

The circuit configuration of I0, I1 is shown as follows:

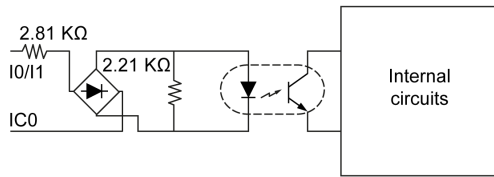

The circuit configuration from I2 to I11 is shown as follows:

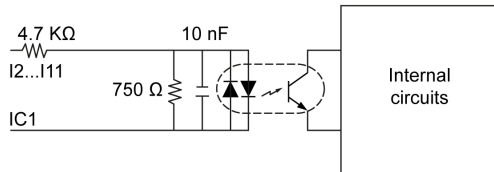

The circuit configuration of Q0 and Q1 is shown as follows:  
It is source type

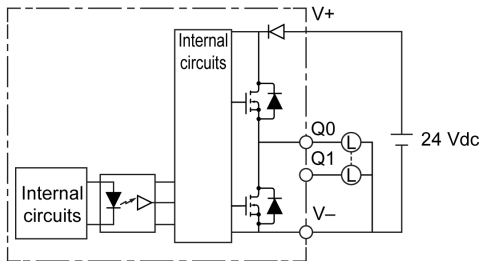

The circuit configuration from Q2 to Q7 is shown as follows:  
It is source type

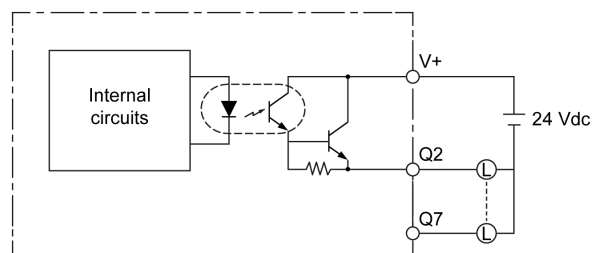

The circuit configuration of Q0 and Q1 is shown as follows:  
It is sink type

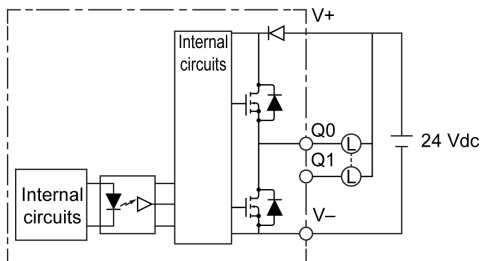

The circuit configuration from Q2 to Q7 is shown as follows:  
It is sink type

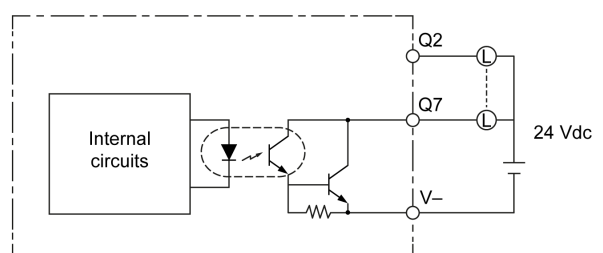

---

## Memory and Touch Panel

### Memory

The table shows the memory specifications of LT:

Items	Specification
Application memory <sup>(1)</sup>	FLASH EPROM 16 MB (Includes screen editing program and extended logic program)
Logic program area	FLASH EPROM 132 KB <sup>(2)</sup> (equivalent to 15,000 steps)
Front area	FLASH EPROM 8 MB (when limit exceeded, uses application memory)
Data backup	nvSRAM 128 KB
Variable area	nvSRAM 64 KB
(1) Capacity available for user application.	
(2) Up to 60,000 steps can be converted in software. However, this reduces application memory capacity (for screen data) by 1 MB.	

### Data Back-Up Management

This memory saves data even when the LT is turned OFF. Upon user request, the setting can be changed through software application.

### Touch Panel

The table shows the touch-panel specifications of LT:

Items	Specification
Type	Resistive film (analog)
Lifetime	1 million touches or more

---

# Chapter 11

## Maintenance

---

### Overview

This chapter explains how to maintain your LT units.

### What Is in This Chapter?

This chapter contains the following topics:

Topic	Page
Regular Cleaning	142
Periodic Check Points	143

---

## Regular Cleaning

### Cleaning the Display

<b><i>NOTICE</i></b>
----------------------

<b>EQUIPMENT DAMAGE</b>
-------------------------

- |                                                                                                                                                                                                                                                                                                            |
|------------------------------------------------------------------------------------------------------------------------------------------------------------------------------------------------------------------------------------------------------------------------------------------------------------|
| <ul style="list-style-type: none"><li>● Power off the unit before cleaning it.</li><li>● Do not use hard or pointed objects to operate the touch panel since it can damage the panel surface.</li><li>● Do not use paint thinner, organic solvents, or a strong acid compound to clean the unit.</li></ul> |
|------------------------------------------------------------------------------------------------------------------------------------------------------------------------------------------------------------------------------------------------------------------------------------------------------------|

<b>Failure to follow these instructions can result in equipment damage.</b>
-----------------------------------------------------------------------------

When the surface or the frame of the display gets dirty, soak a soft cloth in water with a neutral detergent, wring the cloth tightly, and wipe the display.

## Periodic Check Points

### Operation Environment

Refer to the Environmental Specifications (*see page 28*).

### Electrical Specifications

The input voltage must be within 20.4 to 28.8 Vdc.

### Related Items

- Are all power cords and cables connected properly? Are there any loose cables?
- Are all display installation nuts holding the unit securely?







## C

communication interface, *117*

## E

electrical requirements  
installation, *75*

ethernet  
cable port connector, *118*

## G

grounding the system, *36*

## I

I/O management, *43*

installation, *53*  
electrical requirements, *75*  
mechanical requirements, *54*

## L

LT-4201TM/4301TM (Modular Type Analog), *99*

LT-4201TM/4301TM (Modular Type DIO),  
*91*

## M

maintenance  
check points, *143*  
mechanical requirements  
installation, *54*

## P

power supply characteristics and wiring, *76*

## S

specifications  
display, *129*  
general, *126*

## U

USB

data transfer cable, *83*  
driver installation, *83*  
type A, *84*  
type mini-B, *86*